

komi

Your Supply Chain Partner



## **HEAD OFFICE**

Konak Mah. 1. Badem Sk. Lotus Plaza B Blok  
1. Kat Daire:6 No:26 ZIP:16110 Nilüfer  
Bursa / Türkiye

+90 555 880 23 16  
office@komiteks.com  
www.komiteks.com



## **KOMI**

KOMI supply materials for mattress and sofa producers worldwide with it's unique system.

- ✓ KOMI products provide the price/cost advantage and quality together.
  - ✓ KOMI products are produced in Türkiye.
  - ✓ KOMI ensure the same quality in each order for each product group.
- ✓ KOMI provides short delivery times in your orders.
- ✓ You can place your orders via [www.komiteks.com](http://www.komiteks.com)

# INDEX

<b>Nonwoven</b> .....	<b>1</b>
<b>Mattress Edge Tape</b> .....	<b>3</b>
<b>Elastic Webbing</b> .....	<b>5</b>
<b>Mattress Border &amp; Sofa Fabrics</b> .....	<b>7</b>
<b>Bedding Fabric</b> .....	<b>9</b>
<b>Mattress Quilted Fabrics</b> .....	<b>11</b>
<b>Mattress &amp; Mattress Cover</b> .....	<b>17</b>
<b>Spring</b> .....	<b>23</b>
<b>Foam</b> .....	<b>29</b>
<b>Felt</b> .....	<b>35</b>
<b>Fiber Wadding</b> .....	<b>39</b>
<b>Pillow &amp; GUILT</b> .....	<b>45</b>
<b>Foam Wicks</b> .....	<b>47</b>
<b>Air Capsules</b> .....	<b>59</b>
<b>Avangarde Leg</b> .....	<b>67</b>
<b>Metal Leg</b> .....	<b>107</b>
<b>Mechanism</b> .....	<b>123</b>
<b>Argon Welding Wire</b> .....	<b>139</b>
<b>Staple</b> .....	<b>141</b>
<b>Nails</b> .....	<b>145</b>
<b>Buttons &amp; Capsules</b> .....	<b>157</b>
<b>Zibber</b> .....	<b>163</b>
<b>Hook &amp; Loop</b> .....	<b>177</b>



# NONWOVEN



## Nonwoven

- ✓ It can be produced in any grammage between 10g/m<sup>2</sup> and 120g/m<sup>2</sup>
- ✓ It can be produced in any width between 10 cm and 320 cm.
- ✓ More than 20 standart colors always in production including white, black and beige.
- ✓ We can produce it in the desired colors.
- ✓ It is sold based on its weight in kilograms.
- ✓ It is provided in rolls with a length between 50 meters and 10.000 meters.



# MATTRESS EDGE TAPE



## Mattress Edge Tape

- ✓ The standart width for this product is 40-45 mm and its grammage is 8.5 gr.
- ✓ It can be produced in the desired length, color, and grammage.



# ELASTIC WEBBING

## Elastic Webbing

✓ It can be produced in the desired color and stretching rate.



ITEM CODE	THICKNESS	STRETCHING RATE	LINE NUMBER	TIRE NUMBER	MOSTLY USAGE
EW 150100	50 mm	100 %	Single Tire	Single Tire	Back Area
EW 25060	50 mm	60 %	Two Tires	Single Tire	Back Area
EW 35050	50 mm	50 %	Three Tires	Two Tires	Sitting Area
EW 45040	50 mm	40 %	Four Tires	Three Tires	Sitting Area
EW 160100	60 mm	100 %	Single Tire	Single Tire	Back Area
EW 26060	60 mm	60 %	Two Tire	Single Tire	Back Area
EW 36050	60 mm	50 %	Three Tires	Two Tires	Sitting Area
EW 46040	60 mm	40 %	Four Tires	Three Tires	Sitting Area
EW 170100	70 mm	100 %	Single Tire	Single Tire	Back Area
EW 27060	70 mm	60 %	Two Tires	Single Tire	Back Area
EW 37050	70 mm	50 %	Three Tires	Two Tires	Sitting Area
EW 47040	70 mm	40 %	Four Tires	Three Tires	Sitting Area
EW 180100	80 mm	100 %	Single Tire	Single Tire	Back Area
EW 28060	80 mm	60 %	Two Tires	Single Tire	Back Area
EW 38050	80 mm	50 %	Three Tires	Two Tires	Sitting Area
EW 48040	80 mm	40 %	Four Tires	Three Tires	Sitting Area



## **MATTRESS BORDER & SOFA FABRICS**



## Mattress Border & Sofa Fabrics

- ✓ It is used for the production of armchairs, sofas, headboards and chairs.
- ✓ Special color can be also produced, if you request.



# BEDDING FABRIC



SEE OUR  
MORE THAN  
500 FABRICS  
IN OUR  
WEBSITE!

## Knitted Bedding Fabric

- ✓ Used in mattress production, Knitted Bedding Fabrics are produced with a grammage between 140 gr. and 900gr. These items are produced by subjecting 900gr. them to the finishing process.
- ✓ They can be produced with a width between 210 cm and 240 gr.
- ✓ They can be produced in the desired weight, color, length and design.

## Weave Bedding Fabric

- ✓ Used in mattress production, Weaving Bedding Fabrics are produced with a grammage between 70 gr. and 400 gr. These item are produced by subjecting them to the finishing process.
- ✓ They can be produced in 210 cm width.
- ✓ They can be produced in the desired weight, color, length and design.



# MATTRESS QUILTED FABRIC



## Mattress Quilted Fabric

- ✓ Although it can vary as per order, it is a product created by adding interlining at the lowest layer that supported with foam or fiber, using either knitted or weaving mattress fabric.
- ✓ The products to be used and their features are determined by the companies.
- ✓ Any special desing can be quilted instead of the designs, in the next pages.

# Mattress Quilted Fabric



Q 1616



Q 1618



Q 1619



Q 1620



Q 1621



Q 1622

## Mattress Quilted Fabric



Q 1623



Q 1624



Q 1625



Q 1626

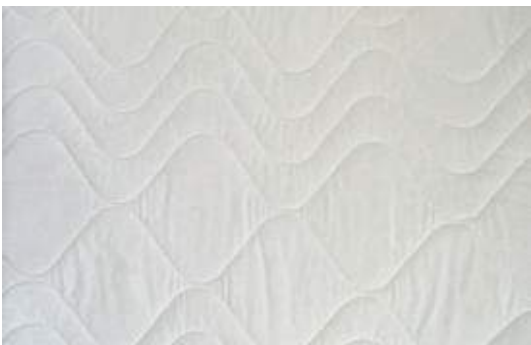

Q 1628



Q 1629

## Mattress Quilted Fabric

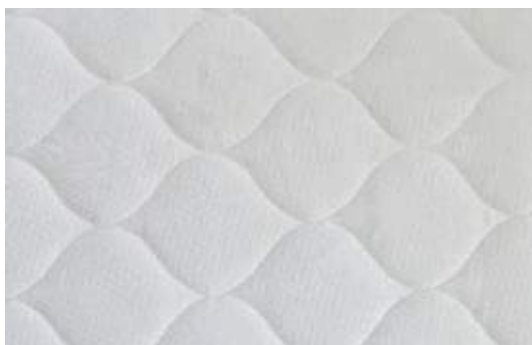

Q 1630



Q 1631

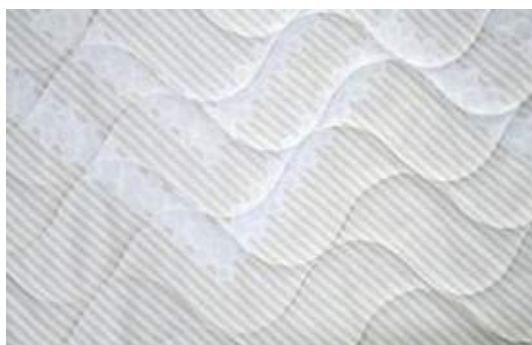

Q 1632



Q 1633



# MATTRESS & MATTRESS COVER



## Mattress Cover

- ✓ We produce quilted or non-quilted mattress-mattress covers in all desired sizes and specifications.

## Mattress Cover



MC 1616



MC 1617



MC 1618



MC 1619



MC 1620



MC 1621

## Mattress Cover



MC 1623



MC 1624



MC 1625



MC 1626



MC 1627



MC 1628

## Mattress Cover



MC 1629



MC 1630



MC 1631



MC 1632



MC 1639



MC 1640

## Mattress Cover



MC 1641



MC 1646



MC 1648



MC 1622



MC 1637



MC 1644



**SPRING**

[www.komiteks.com](http://www.komiteks.com)



## Standart Pocket Spring - 672 Counts

- ✓ Top & Bottom or Center Glued available
- ✓ Round Frame (Separate) - Flat Frame available as attachment System
- ✓ All sizes and zone systems available
- ✓ Meets all standart requirements
- ✓ Reliable System

ITEM CODE	SPECIFICATION	WIRE DIAMETER	HEIGHT	SPRING/M2	PRODUCT
SPS 672	672 Count	1,70 mm - 2,00 mm	140 mm - 200 mm	224	Standart Pocket Spring



## Standart Pocket Spring - 800 Counts

- ✓ Top & Bottom or Center Glued available
- ✓ Round Frame (Separate) - Flat Frame available as attachment System
- ✓ All sizes and zone systems available
- ✓ Meets all standart requirements
- ✓ Reliable System

ITEM CODE	SPECIFICATION	WIRE DIAMETER	HEIGHT	SPRING/M2	PRODUCT
SPS 800	800 Count	1,70 mm - 1,90 mm	140 mm - 200 mm	265	Standart Pocket Spring



## Standart Pocket Spring - 1000 Counts

- ✓ Top & Bottom or Center Glued available
- ✓ Round Frame (Separate) - Flat Frame available as attachment System
- ✓ All sizes and zone systems available
- ✓ Meets all standart requirements
- ✓ Reliable System

ITEM CODE	SPECIFICATION	WIRE DIAMETER	HEIGHT	SPRING/M2	PRODUCT
SPS 1000	1000 Count	1,50 mm - 1,70 mm	140 mm - 200 mm	333	Standart Pocket Spring



## Micro Pocket Spring - 1500 Counts

- ✓ Top & Bottom or Center Glued available
- ✓ Round Frame (Separate) - Flat Frame available as attachment System
- ✓ All sizes and zone systems available
- ✓ Meets all standart requirements
- ✓ Reliable System

ITEM CODE	SPECIFICATION	WIRE DIAMETER	HEIGHT	SPRING/M2	PRODUCT
MCPS 1500	1500 Count	1,30 mm - 1,50 mm	140 mm - 200 mm	500	Micro Pocket Spring



## Micro Pocket Spring - 1600 Counts

- ✓ Top & Bottom or Center Glued available
- ✓ Round Frame (Separate) - Flat Frame available as attachment System
- ✓ All sizes and zone systems available
- ✓ Meets all standart requirements
- ✓ Reliable System

ITEM CODE	SPECIFICATION	WIRE DIAMETER	HEIGHT	SPRING/M2	PRODUCT
MCPS1600	1600 Count	1,30 mm - 1,50 mm	140 mm - 200 mm	566	Micro Pocket Spring



## Micro Pocket Spring - 2000 Counts

- ✓ Top & Bottom or Center Glued available
- ✓ Round Frame (Separate) - Flat Frame available as attachment System
- ✓ All sizes and zone systems available
- ✓ Meets all standart requirements
- ✓ Reliable System

ITEM CODE	SPECIFICATION	WIRE DIAMETER	HEIGHT	SPRING/M2	PRODUCT
MCPS 2000	2000 Count	1,10 mm - 1,50 mm	140 mm - 200 mm	667	Micro Pocket Spring



## Mini Pocket Spring - 1500 Counts

- ✓ Top & Bottom or Center Glued available
- ✓ All sizes available
- ✓ Special desing for topper production

ITEM CODE	SPECIFICATION	WIRE DIAMETER	HEIGHT	SPRING/M2	PRODUCT
MNPS 1500	1500 Count	1,20 mm - 1,30 mm	50 mm - 80 mm	500	Mini Pocket Spring



## Mini Pocket Spring - 2000 Counts

- ✓ Top & Bottom or Center Glued available
- ✓ All sizes available
- ✓ Special desing for topper production

ITEM CODE	SPECIFICATION	WIRE DIAMETER	HEIGHT	SPRING/M2	PRODUCT
MNPS 2000	2000 Count	1,10 mm - 1,20 mm	50 mm - 80 mm	667	Mini Pocket Spring



# FOAM

## Standart / Hard Foam



- ✓ Foams with a density ranging between 14 and 35 are used in the production of armchairs, sofas, beds, and bed bases to provide softness to their seats and backrests.

14 DNS	HARD	Item Code : FH 14
14 DNS	STANDART	Item Code : FS 14
18 DNS	HARD	Item Code : FH18
18 DNS	STANDART	Item Code : FS 18
22 DNS	HARD	Item Code : FH 22
22 DNS	STANDART	Item Code : FS 22
24 DNS	HARD	Item Code : FH 24
24 DNS	STANDART	Item Code : FS 24
26 DNS	HARD	Item Code : FH 26
26 DNS	STANDART	Item Code : FS 26
28 DNS	HARD	Item Code : FH 28
28 DNS	STANDART	Item Code : FS 28
30 DNS	HARD	Item Code : FH 30
30 DNS	STANDART	Item Code : FS 30
32 DNS	HARD	Item Code : FH 14
32 DNS	STANDART	Item Code : FS 32
35 DNS	HARD	Item Code : FH 35
35 DNS	STANDART	Item Code : FS 35

## Visco Foam



- ✓ Visco foams with a density ranging between 32 and 60 are preferred as luxury foams in the production of mattresses.
- ✓ It is produced from special raw materials. It takes the shape of the body.

32 DNS	VISCO	Item Code : FV 32
40 DNS	VISCO	Item Code : FV 40
50 DNS	VISCO	Item Code : FV 50
60 DNS	VISCO	Item Code : FV 60
70 DNS	VISCO	Item Code : FV 70

## Roll Foam



- ✓ Foam Rolls are produced with a density of 14 and 18..
- ✓ It is used in the production of the armchairs, sofas, beds and bed bases to provide softness to their seats and backrests.
- ✓ Roll packaging service is provided.

14 DNS	ROLL FOAM	Item Code : RF 14
18 DNS	ROLL FOAM	Item Code : RF 18

## Bondex Foam



- ✓ Bondex (Rebonded Foam) is a sponge group material that is flexible and dense in nature, produced by recycling scrap sponges.

50 DNS	BONDEX	Item Code : BF 50
60 DNS	BONDEX	Item Code : BF 60
100 DNS	BONDEX	Item Code : BF 100



# FELT

## Hard Felt

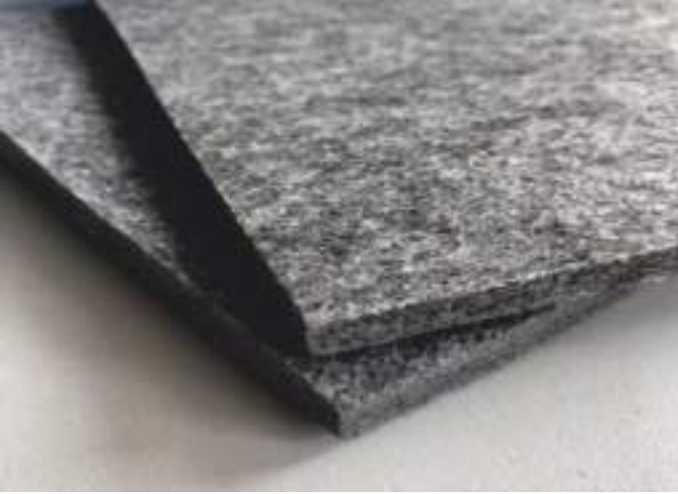

ITEM CODE
HF 1616

✓ It is produced in the grammage between 400 g/m and 2000 g/m .<sup>2</sup>

## Roll Felt



ITEM CODE
RF 1616

✓ It is produced in the grammage between 400 g/m<sup>2</sup> and 2000 g/m<sup>2</sup>.

## White Felt

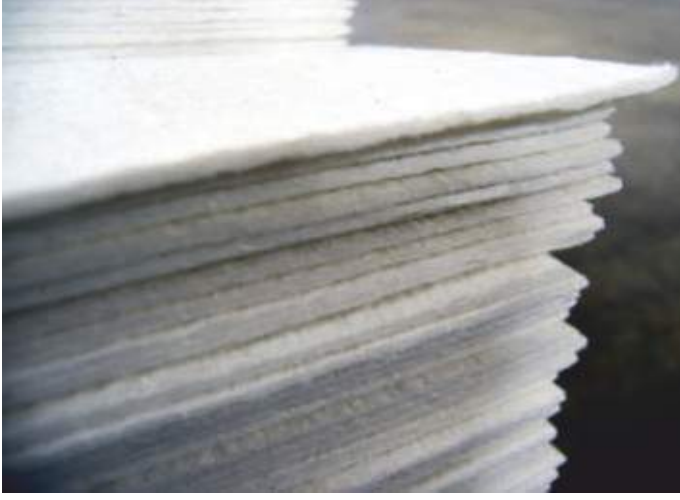

ITEM CODE
WF 1616

- ✓ It is produced in desired size or in rolls in the range of 400-1500gr/m .<sup>2</sup>
- ✓ White Felt is a completely hygienic product with an anti-bacterial structure produced with %100 original polyester raw material.

## Soft Felt



ITEM CODE
SF 1616

- ✓ It is produced in desired size or in rolls in the range of 400-1500 gr/m<sup>2</sup>
- ✓ Termobond felt is applied on the sofa and sofa groups and provides sound insulation and comfort.
- ✓ Soft and flexible structure provides ease of production processes.
- ✓ It provides ease of production with its flexible structure.

## Jute Felt



ITEM CODE
JF 1616

- ✓ It is produced in the grammage between 800 g/m<sup>2</sup> and 1500 g/m<sup>2</sup>.



# FIBER & WADDING

## Laminated Wadding Fiber



ITEM CODE
LWF 1616

- ✓ Laminated Wadding, which has a durable structure and a fairly soft shade, is produced by laminating felt under the silicon wadding.
- ✓ It is often used in the furniture upholstery industry.
- ✓ Our company is able to produce Laminated Wadding from 60 gr/m<sup>2</sup> to 1000 gr/m<sup>2</sup> and a width of 3.2 mt

## Original Wadding Fiber

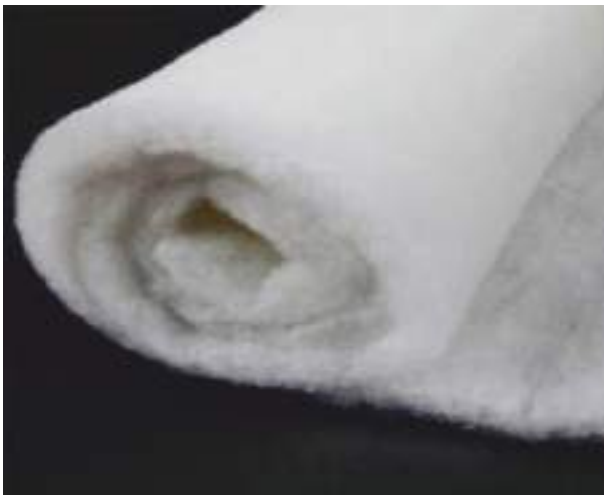

ITEM CODE
OWF 1616

- ✓ Produced from virgin original fiber.
- ✓ It can be prepared at desired weight and width as well as desired firmness and softness.
- ✓ It is commonly used in the furniture upholstery industry, home textile, quilting, apparel and bedding.
- ✓ Our company is able to produce Original Wadding from 60 gr/m<sup>2</sup> to 1000 gr/m<sup>2</sup> and a width of 3.2 mt

## Regenerated Wadding Fiber

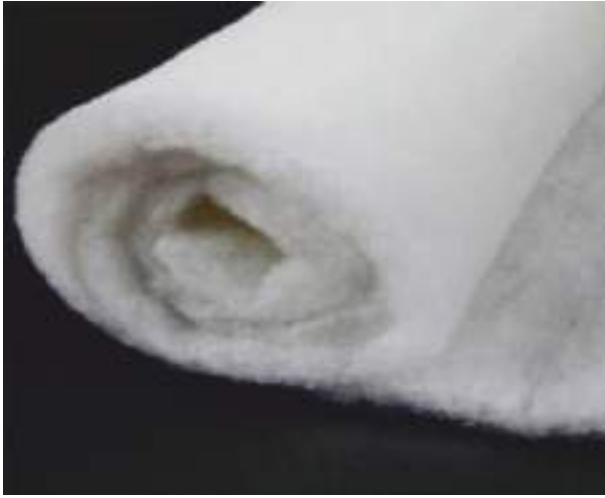

ITEM CODE
RWF 1616

- ✓ Produced from virgin regenerated fibre, this wadding can be prepared at desired weight and width as well as desired firmness and softness.
- ✓ Our products are commonly used in furniture home textile, quilting and bedding industry.
- ✓ It is produced in rolls according to customer request in the range of 60 gr/m<sup>2</sup> -1000 gr/m<sup>2</sup>.

## Slicone Wadding Fiber

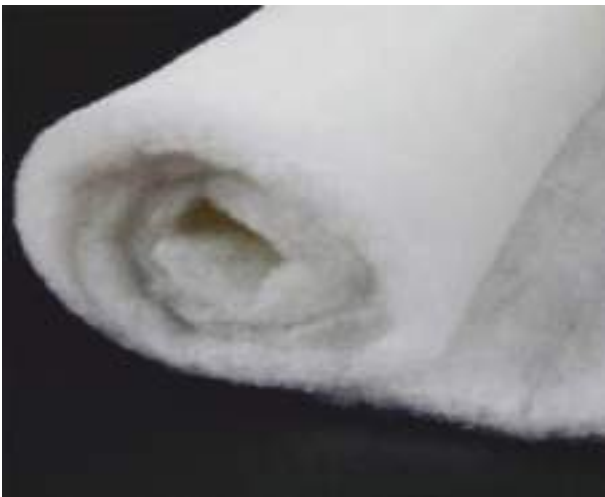

ITEM CODE
SWF 1616

- ✓ Produced from sliconised fiber, this wadding can be prepared at desired weight and width as well as desired firmness and softness.
- ✓ Our products are commonly used in furniture home textile, quilting and in bedding industry.
- ✓ It is produced in rolls according to customer request in the range of 60 gr/m<sup>2</sup> -1000 gr/m<sup>2</sup>.

## Flare Wadding Fiber

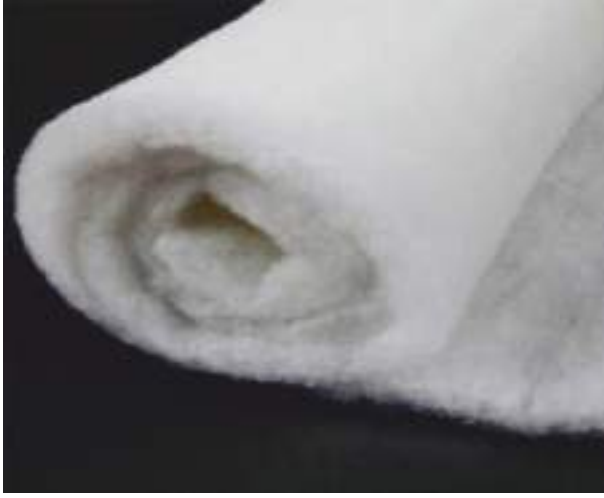
**ITEM CODE**

FWF 1616

- ✓ The Flare Wadding, which is prepared with a special fiber mixture using a chemical additive, is usually used as a filler in the production of furniture and beds produced for foreign Sundays.
- ✓ It can be produced at the desired hardness of softness.
- ✓ Our products are commonly used in furniture, home textile, quilting in bedding dustry.
- ✓ It is produced in rolls according to customer request in the range of 60 gr/m<sup>2</sup> -1000 gr/m<sup>2</sup>.

## Flame Retardant Wadding

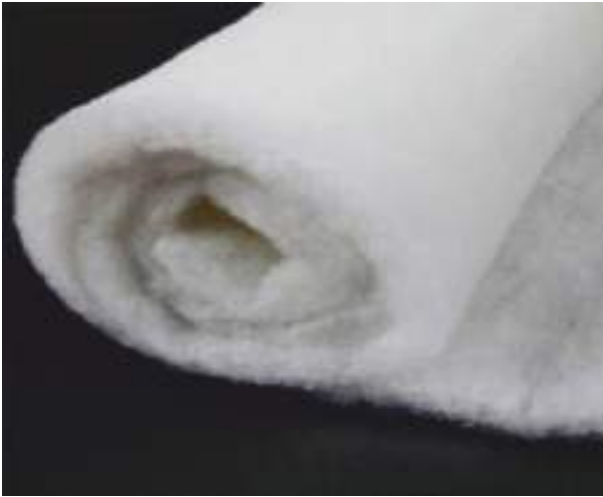
**ITEM CODE**

FRW 1616

- ✓ This type of fibre is produced from both original and regenerated raw material has a flame reterdant characteristics.
- ✓ Our products are commonly used in furniture, home textile, quilting in bedding dustry.
- ✓ It is produced in rolls according to customer request in the range of 60 gr/m<sup>2</sup> -1000 gr/m<sup>2</sup>.

## Wool Wadding

**ITEM CODE**

WW 1616

- ✓ It is produced as a roll in range of 300-1500 gr/m<sup>2</sup>.
- ✓ %100 Natural Sheep wool wadding is odorless and hygienic structure provides heat balance in your products. It helps to maintain the heat balance by using on the winter side of the bearings. The carefully selected wool raw material is washed in eight-stage special washing pools to remove foreign matter and odor. Provides natural structure and non-flammability.

## Cotton Wadding

**ITEM CODE**

CW 1616

- ✓ It is produced in rolls in the range of 350-1500 gr/m<sup>2</sup>
- ✓ Cotton wadding adds value to your products with its special and hygienic structure, keeps the heat exchange in the body in balance. It helps to find the heat balance by evaluating the summer face of the beds.

## Slicon Fiber Bead



ITEM CODE
SFB 1616

- ✓ Due to the special raw material in its Snowflake Fiber Structure, it has the feature of a spring. It provides a great advantage to be used as a filler compared to other synthetic paddings due to the high volume and low weight it possesses after machine processes. Due to its small and lithe structure, it can penetrate all corners in places where it is used as filling material. Thanks to this feature, it provides great convenience in filling work and homogeneous distribution.
- ✓ It is sold in standart nylon with or without vacuum.
- ✓ It is sold as kg.

## Slicon Fiber Flat



ITEM CODE
SFF 1616

- ✓ Spun Polyester Fiber can be produced in any denier between 1,5 denier and 35 denier.
- ✓ It can produced also in any lenght between 25 mm and 150 mm
- ✓ Special color study also can be done with customer request.



# PILLOW & QUILT

## Regular Pillow

ITEM CODE
-----------

RP 1616
---------

- ✓ It can be produced in any size desired
- ✓ The exterior fabric can be felt or a fabric desired.
- ✓ Interior material can be feather, fiber, fibel balls, clipped fiber according to the request.
- ✓ Interior material can be mix and mix ratio can be determined according to the request.



## Lace Pillow For Furniture

ITEM CODE
-----------

LP 1616
---------

It is the products used by sofa makers in pillows

- ✓ It can be produced in any size desired
- ✓ The exterior fabric can be felt or a fabric desired.
- ✓ Interior material can be feather, fiber, fibel balls, clipped fiber, regular foam, flipped foam according to the request.
- ✓ Interior material can be mix and ratio can be determined according to the request.

## Quilt

ITEM CODE
-----------

Q 1616
--------

- ✓ It can be produced in any size desired
- ✓ The exterior fabric can be felt or a fabric desired.
- ✓ Interior material can be feather, fiber, fiber balls, according to the request.
- ✓ Interior material can be mix and mix ratio can be determined according to the request.



# FOAM WICKS

## Multipurpose B1 Profile



Can be manufactured with different shape, dimension and colors.

ITEM CODE	DIAMETER ( MM )	PRODUCT
MB1P 8	8	Multipurpose B1 Profile
MB1P 12	12	Multipurpose B1 Profile
MB1P 14	14	Multipurpose B1 Profile
MB1P 16	16	Multipurpose B1 Profile
MB1P 18	18	Multipurpose B1 Profile
MB1P 20	20	Multipurpose B1 Profile
MB1P 22	22	Multipurpose B1 Profile
MB1P 25	25	Multipurpose B1 Profile

## Piping Cords



Can be manufactured with different shape, dimension and colors.

ITEM CODE	DIAMETER ( MM )	PRODUCT
PC 3	3	Piping Cords
PC 4	4	Piping Cords
PC 5	5	Piping Cords
PC 6	6	Piping Cords
PC 7	7	Piping Cords
PC 8	8	Piping Cords
PC 10	10	Piping Cords

## Multipurpose O Profile



- ✓ Can be manufactured with different shape, dimension and colors.

ITEM CODE	DIAMETER ( MM )	PRODUCT
MOP 12	12	Multipurpose O Profile
MOP 19	19	Multipurpose O Profile
MOP 25	25	Multipurpose O Profile

## Multipurpose D Profile



- ✓ Can be manufactured with different shape, dimension and colors.

ITEM CODE	DIAMETER ( MM )	PRODUCT
MDP 10	10	Multipurpose D Profile
MDP 14	14	Multipurpose D Profile
MDP 15	15	Multipurpose D Profile
MDP 17	17	Multipurpose D Profile
MDP 20	20	Multipurpose D Profile
MDP 25	25	Multipurpose D Profile

## Multipurpose B2 Profile



Can be manufactured with different shape, dimension and colors.

ITEM CODE	DIAMETER ( MM )	PRODUCT
MB2P 14	14	Multipurpose B2 Profile
MB2P 16	16	Multipurpose B2 Profile

## Multipurpose B3 Profile



Can be manufactured with different shape, dimension and colors.

ITEM CODE	DIAMETER ( MM )	PRODUCT
MB3P 18	18	Multipurpose B3 Profile
MB3P 25	25	Multipurpose B3 Profile

## V-Profile

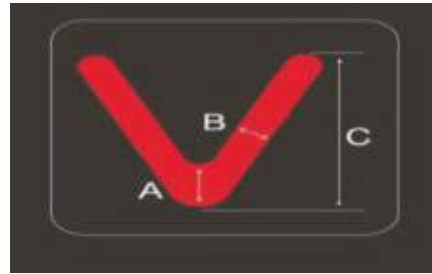

✓ Can be manufactured with different shape,dimension and colors.

ITEM CODE	A	B	C	PRODUCT
VP 50	8	8	50	V Profile
VP 55	12	12	55	V Profile
VP 60	14	14	60	V Profile
VP 70	10	10	70	V Profile
VP 75	16	16	75	V Profile
VP 100	20	20	100	V Profile
VP 180	14	14	180	V Profile

## V - Corner

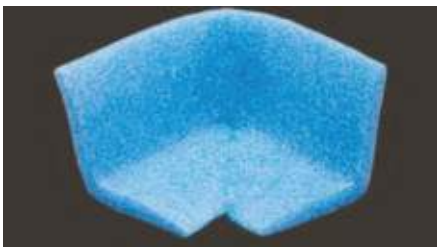

✓ Can be manufactured with different shape, dimension and colors.

ITEM CODE	PRODUCT
VC 1616	V Corner

## V- Corner Block



✓ Can be manufactured with different shape, dimension and colors.

ITEM CODE	PRODUCT
VCB 1616	V Corner Block

## U - Profile

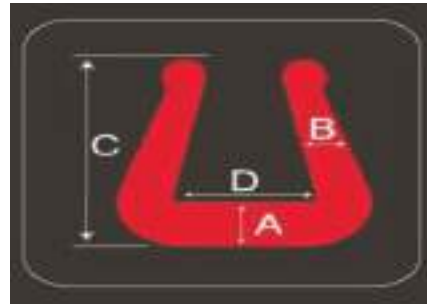

✓ Can be manufactured with different shape, dimension and colors.

ITEM CODE	A	B	C	D	PRODUCT
UP 15	10	10	50	15	U Profile
UP 20	10	10	50	20	U Profile
UP 25	10	10	50	25	U Profile
UP 30	12	10	50	30	U Profile
UP 35	12	10	50	35	U Profile
UP 40	12	10	55	40	U Profile
UP 45	12	10	55	45	U Profile
UP 50	14	10	55	50	U Profile
UP 55	14	12	55	55	U Profile
UP 60	14	14	60	60	U Profile
UP 70	16	16	60	70	U Profile
UP 75	20	14	60	75	U Profile
UP 100	15	14	150	100	U Profile

## U - Closed Mouth



- ✓ Can be manufactured with different shape, dimension and colors.

ITEM CODE	PRODUCT
UCM 1616	U Closed Mouth

## U - Corner



- ✓ Can be manufactured with different shape, dimension and colors.

ITEM CODE	PRODUCT
UC 1616	U Corner

## D - Profile

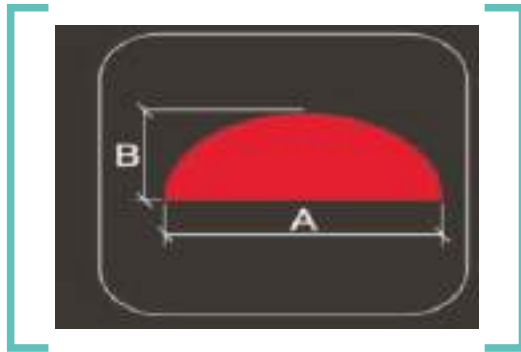
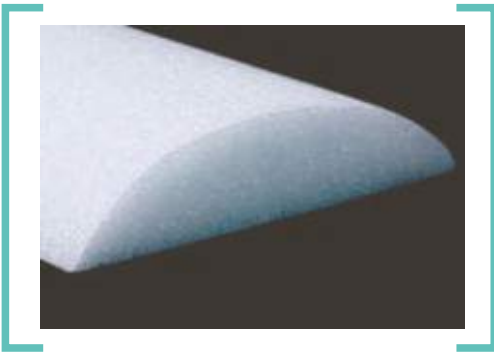

✓ Can be manufactured with different shape, dimension and colors.

ITEM CODE	A	B	PRODUCT
DP 40	40	20	D Profile
DP 50	50	25	D Profile
DP 60	60	30	D Profile
DP 70	70	35	D Profile
DP 80	80	40	D Profile
DP 90	90	45	D Profile
DP 100	100	50	D Profile
DP SPECIAL	--	--	D Profile

## C - Profile

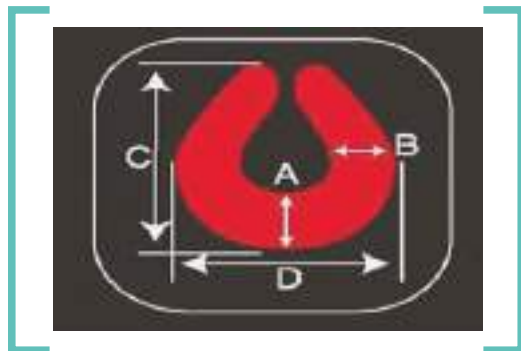
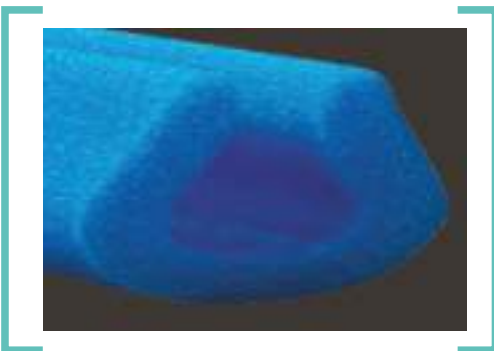

✓ Can be manufactured with different shape, dimension and colors.

ITEM CODE	A	B	C	D	PRODUCT
CP 25	40	20	40	20	C Profile
CP 35	50	25	50	25	C Profile
CP 40	60	30	50	25	C Profile
CP 50	70	35	50	25	C Profile
CP 60	80	40	50	25	C Profile
CP SPECIAL	--	--	--	--	C Profile

## C- Corner



✓ Can be manufactured with different shape, dimension and colors.

ITEM CODE	PRODUCT
CC 1616	C Corner

## O - Profile

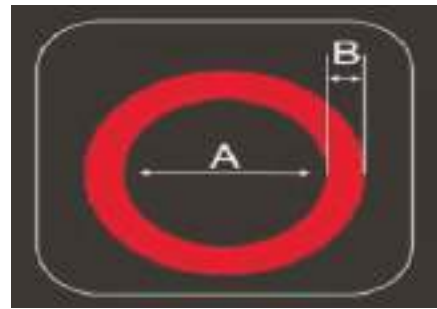
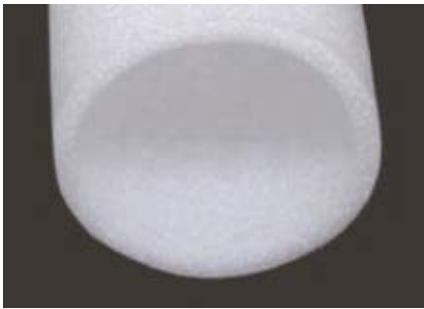

✓ Can be manufactured with different shape, dimension and colors.

ITEM CODE	A	B	PRODUCT
OP 203	20	3	O Profile
OP 253	25	3	O Profile
OP 303	30	3	O Profile
OP 353	35	3	O Profile
OP 403	40	3	O Profile
OP 453	45	3	O Profile
OP 503	50	3	O Profile
OP 703	70	3	O Profile

## Glass - Profile

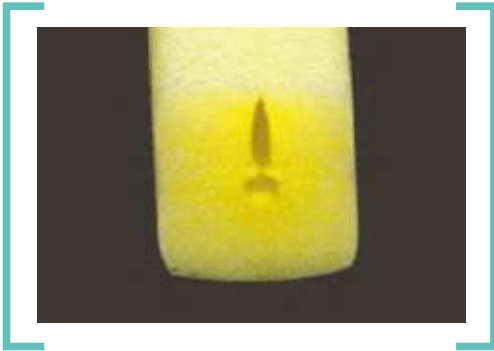

✓ Can be manufactured with different shape, dimension and colors.

ITEM CODE	A	B	C	D	PRODUCT
GP 34	25	34	6	16	Glass Profile
GP 40	30	40	8	18	Glass Profile
GP SPECIAL	--	--	--	--	Glass Profile

## J - Profile

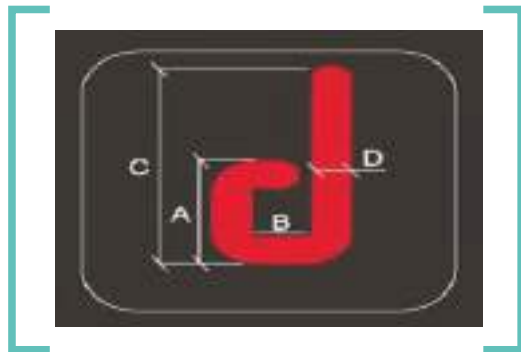

✓ Can be manufactured with different shape, dimension and colors.

ITEM CODE	A	B	C	D	PRODUCT
JP 2590	35	25	90	10	J Profile
JP 25120	35	25	120	10	J Profile
JP 25140	35	25	140	10	J Profile
JP 30140	35	30	140	10	J Profile
GP SPECIAL	--	--	--	--	J Profile

## T - Profile

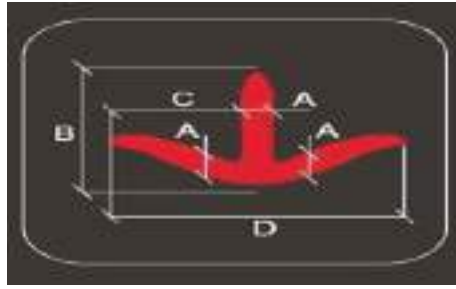

✓ Can be manufactured with different shape, dimension and colors.

ITEM CODE	A	B	C	D	PRODUCT
TP 50	12	62	50	112	T Profile
TP 60	12	72	60	132	T Profile
TP 70	12	82	70	152	T Profile
TP 80	12	92	80	172	T Profile
TP 100	12	112	100	212	T Profile
TP SPECIAL	--	--	--	--	T Profile

## Polythene Sheets



ITEM CODE	A	PRODUCT
PS 1	1	Polythene Sheets
PS 1A	1,5	Polythene Sheets
PS 2	2	Polythene Sheets
PS 3	3	Polythene Sheets
PS 4	4	Polythene Sheets
PS 5	5	Polythene Sheets
PS 8	8	Polythene Sheets
PS 10	10	Polythene Sheets
PS 15	15	Polythene Sheets
PS 20	20	Polythene Sheets
PS 30	30	Polythene Sheets
PS SPECIAL	--	Polythene Sheets

✓ Can be manufactured with different shape, dimension and colors.

## Air Buble Sheets



- ✓ Can be manufactured with different shape, dimension and colors.

ITEM CODE	PRODUCT
ABS 1616	Air Buble Sheets

## Polythene Filling Profiles

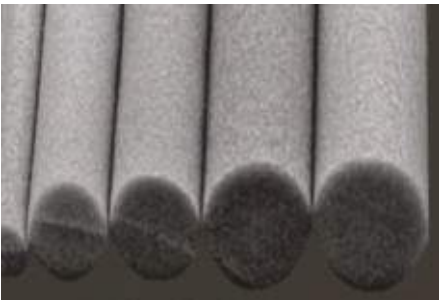

- ✓ Can be manufactured with different shape, dimension and colors.

ITEM CODE	THICKNESS	PRODUCT
PFP 10	10	Polythene Filling Profiles
PFP 15	15	Polythene Filling Profiles
PFP 20	20	Polythene Filling Profiles
PFP 25	25	Polythene Filling Profiles
PFP 30	30	Polythene Filling Profiles
PFP 40	40	Polythene Filling Profiles
PFP 50	50	Polythene Filling Profiles
PFP 60	60	Polythene Filling Profiles
PFP SPECIAL	--	Polythene Filling Profiles



# AIR CAPSULES



## Air Capsules

- ✓ It is used as an accessory to allow air circulation in the mattress.
- ✓ The product is produced in different and customised shapes with 20,40,60 mm and customised too.
- ✓ The colors can be customized too.
- ✓ Company logos can be also printed on the air capsules.



AC 1616



AC 1617

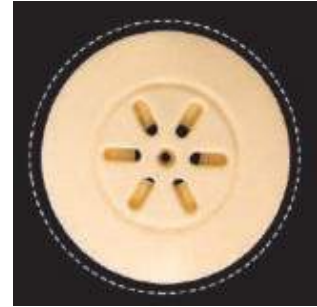

AC 1618



AC 1619



AC 1620



AC 1621



AC 1622



AC 1623



AC 1624



AC 1625



AC 1626



AC 1627



AC 1628



AC 1629



AC 1630



AC 1631



AC 1632



AC 1633



AC 1634



AC 1635



AC 1636



AC 1637



AC 1638



AC 1639



AC 1640



AC 1641



AC 1642



AC 1643



AC 1644



AC 1645



AC 1646



AC 1647



AC 1648



AC 1649



AC 1650



AC 1651



AC 1652



AC 1653



AC 1654



AC 1655



AC 1656

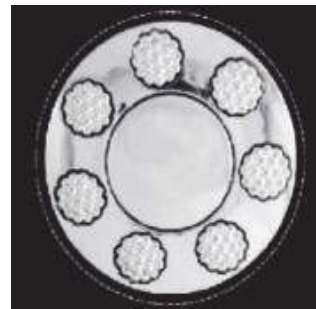

AC 1657



AC 1658



AC 1659



AC 1660



AC 1661



AC 1662

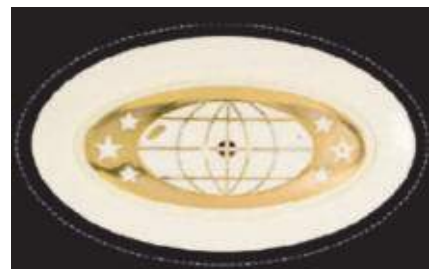

AC 1663



AC 1664

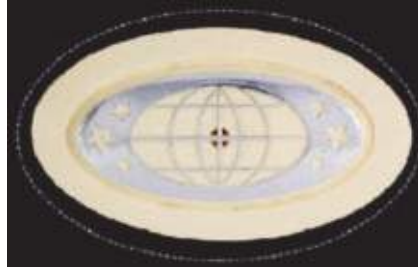

AC 1665

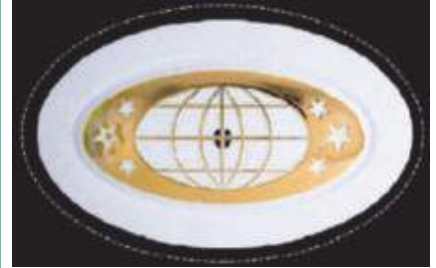

AC 1666

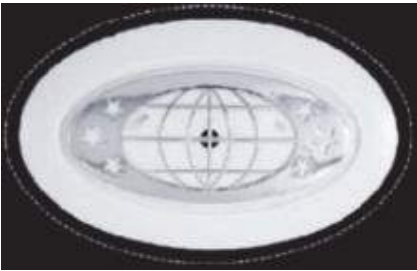

AC 1667



AC 1668



AC 1669



AC 1670



AC 1671



AC 1672



## AVANGARDE LEG

## AL 16 (20 cm)

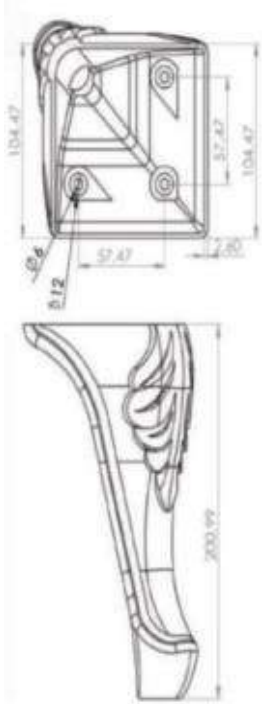

AL 16 A



AL 16 B



AL 16 C



AL 16 D

## AL 17 (20 cm)

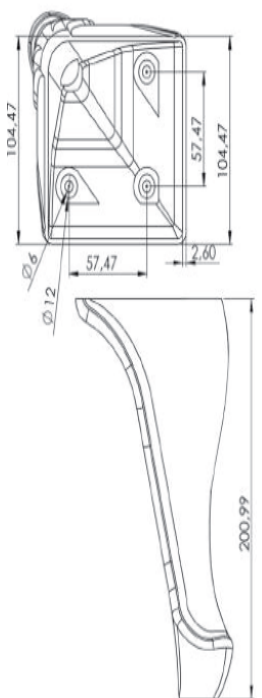

AL 17 A



AL 17 B



AL 17 C



AL 17 D

## AL 18 (24 cm )

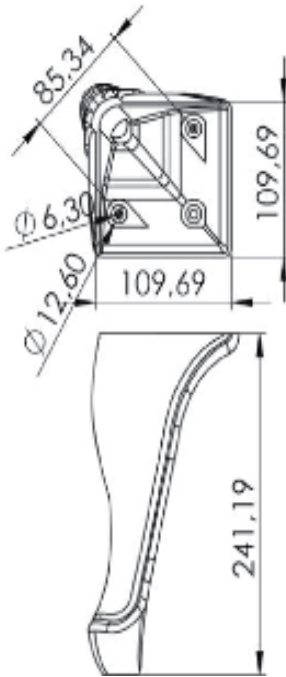

AL 18 A



AL 18 B



AL 18 C



AL 18 D

## AL 19 (14x17 cm )

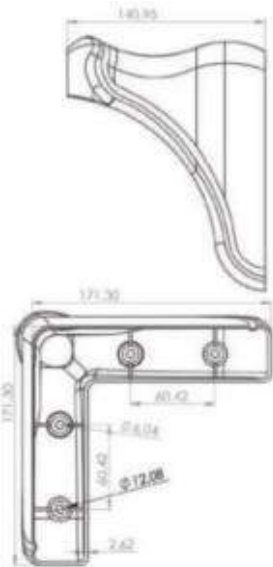

AL 19 A



AL 19 B



AL 19 C



AL 19 D

## AL 20 (12x15 cm)

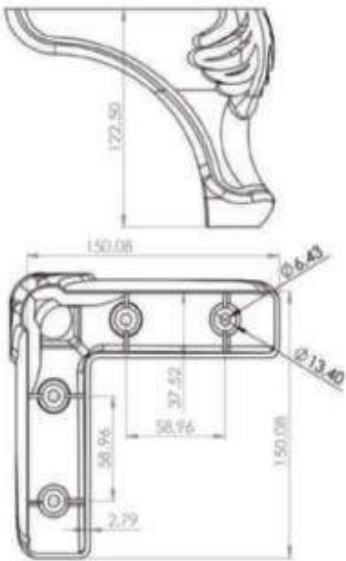

AL 20 A

AL 20 B

AL 20 C

## AL 21 (12x17 cm)

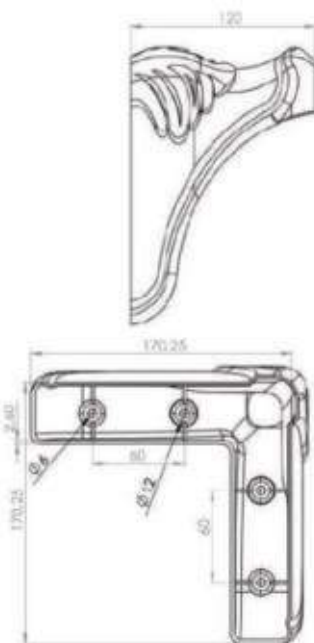

AL 21 A

AL 21 B

AL 21 C

## AL 22 (12x17 cm)

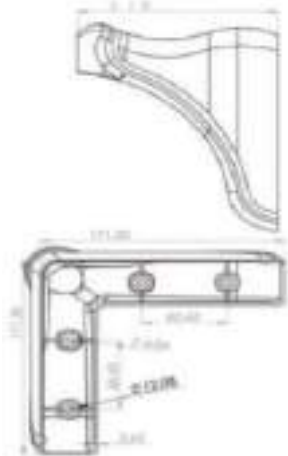

AL 22 A



AL 22 B



AL 22 C

## AL 23 (14x17 cm)

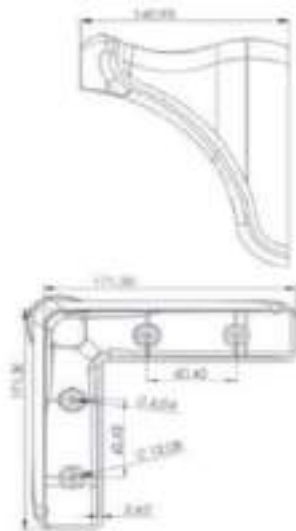

AL 23 A



AL 23 B



AL 23 C

## AL 24 (10x18 cm)

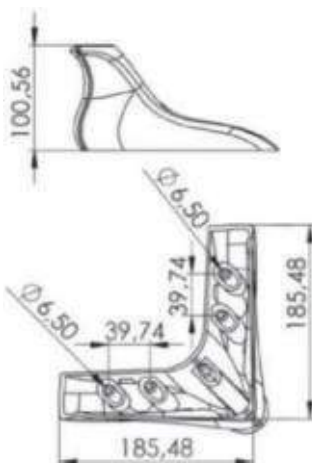

AL 24 A



AL 24 B



AL 24 C

## AL 25

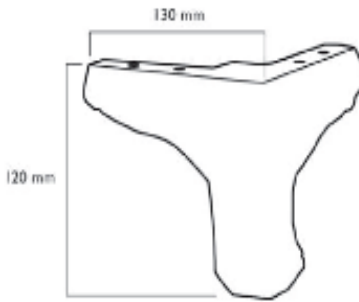

AL 25 A



AL 25 B



AL 25 C

## AL 26 (14 cm)

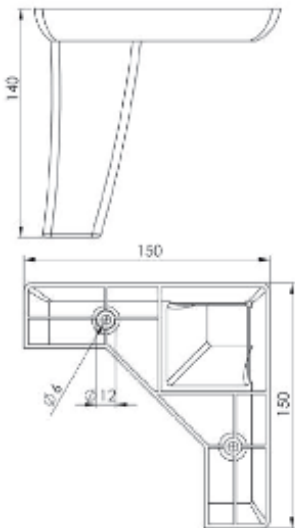

AL 26 A



AL 26 B



AL 26 C

## AL 27

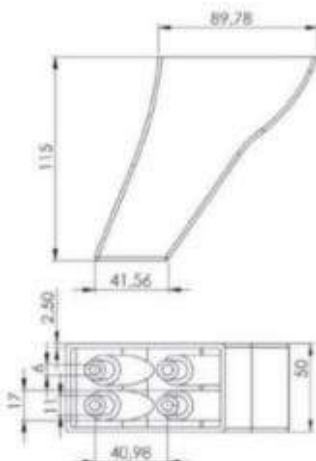

AL 27 A



AL 27 B



AL 27 C

## AL 28

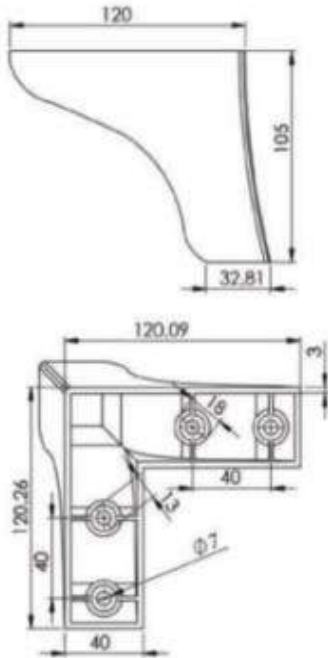

AL 28 A

AL 28 B

AL 28 C

## AL 29 (10 cm)

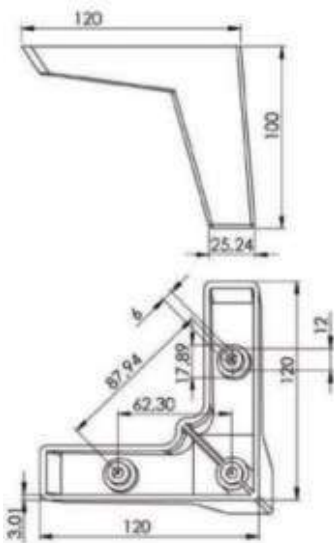

AL 29 A

AL 29 B

AL 29 C

## AL 30 (14cm)

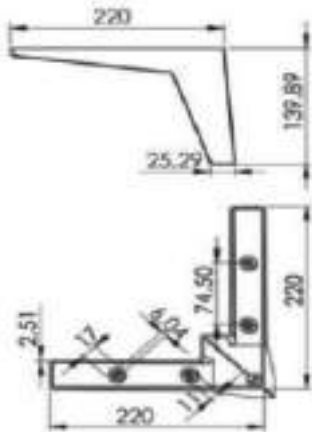

AL 30 A



AL 30 B



AL 30 C

## AL 31 (9cm)

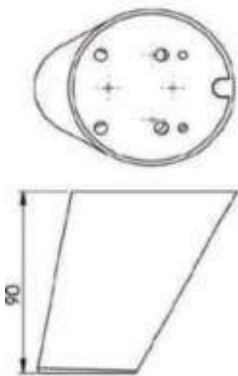

AL 31 A



AL 31 B



AL 31 C



AL 31 D

## AL 32 (7cm)

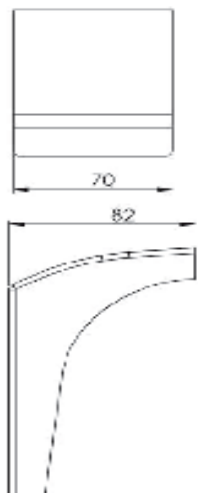

AL 32 A



AL 32 B



AL 32 C



AL 32 D

## AL 33 (12cm)

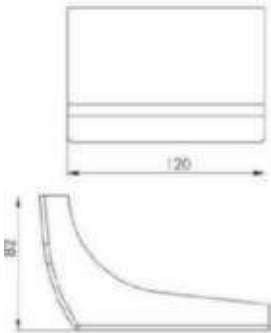

AL 33 A

AL 33 B

AL 33 C

AL 33 D

## AL 34 (14cm)

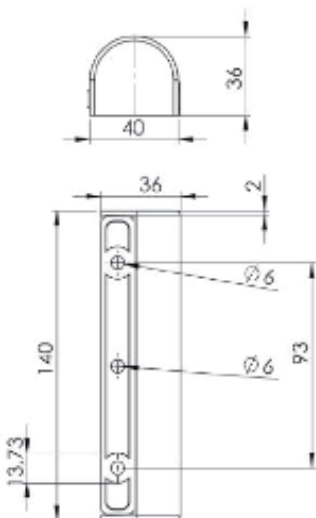

AL 34 A

AL 34 B

AL 34 C

## AL 35 (18cm)

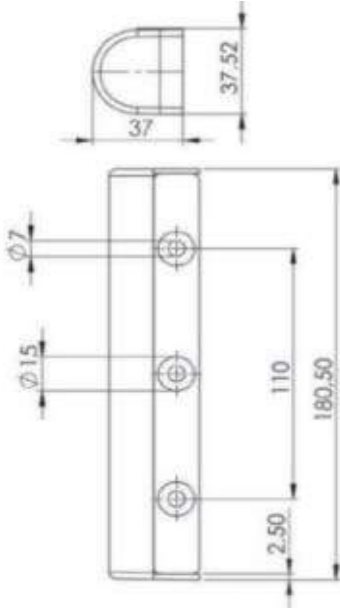

AL 35 A

AL 35 B

AL 35 C

## AL 36 (22cm)

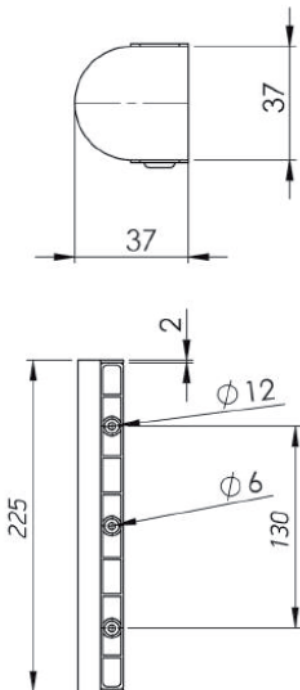

AL 36 A

AL 36 B

AL 36 C

## AL 37 (27 cm)

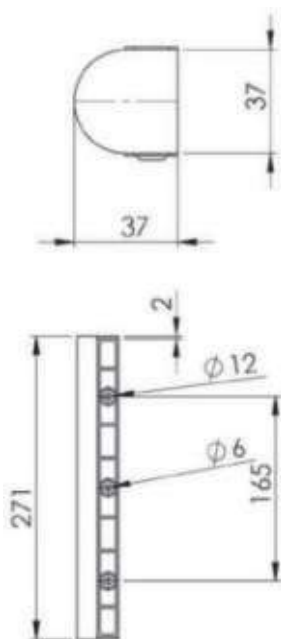

AL 37 A



AL 37 B



AL 37 C

## AL 38 (16 cm)

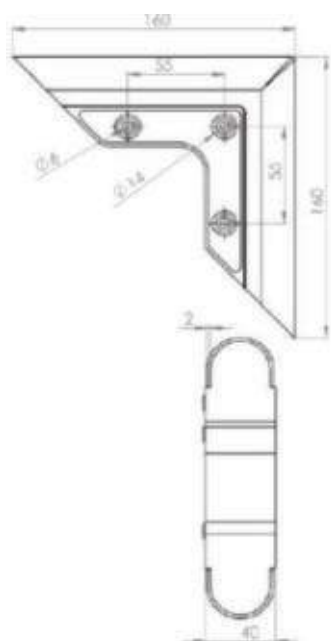

AL 38 A



AL 38 B



AL 38 C

## AL 39

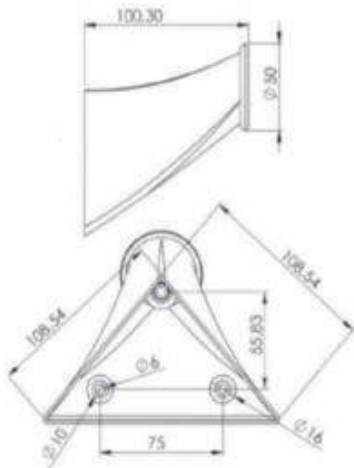

AL 39 A



AL 39 B



AL 39 C

## AL 40

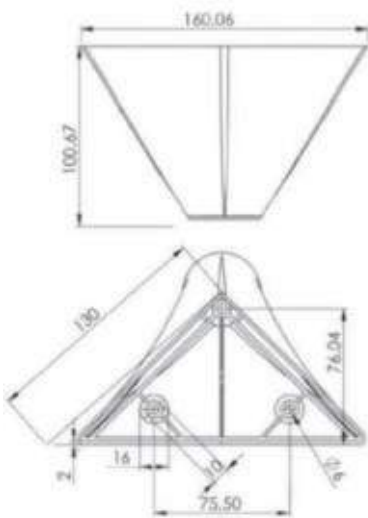

AL 40 A



AL 40 B



AL 40 C

## AL 41 (18 cm)

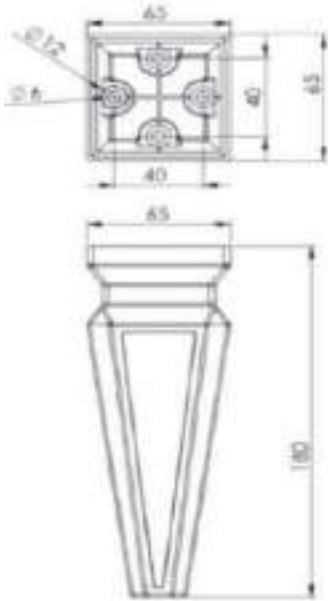

AL 41 A



AL 41 B



AL 41 C

## AL 42 (14cm)

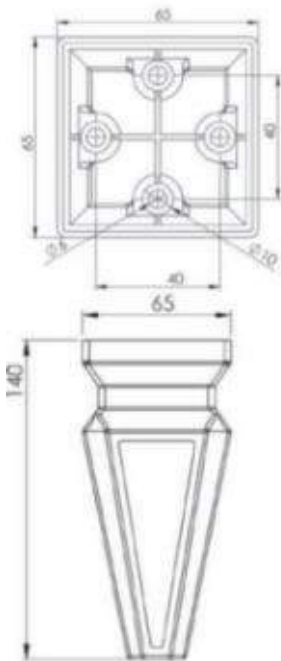

AL 42 A



AL 42 B



AL 42 C

## AL 43 (35 cm)

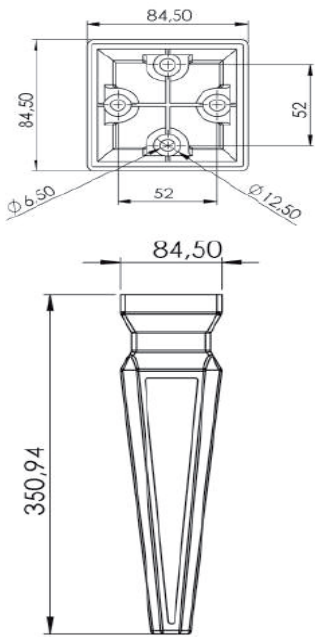

AL 43 A



AL 43 B



AL 43 C

## AL 44 (18 cm)

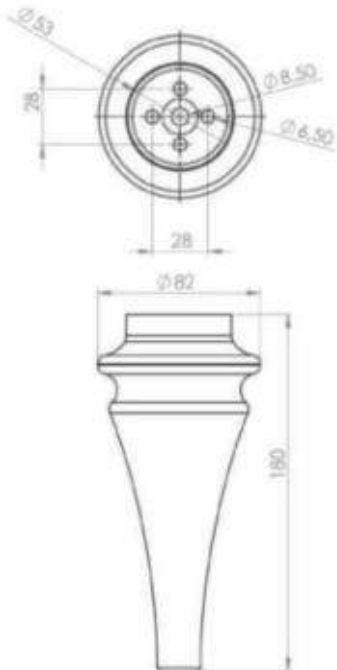

AL 44 A



AL 44 B

## AL 45 (14 cm)

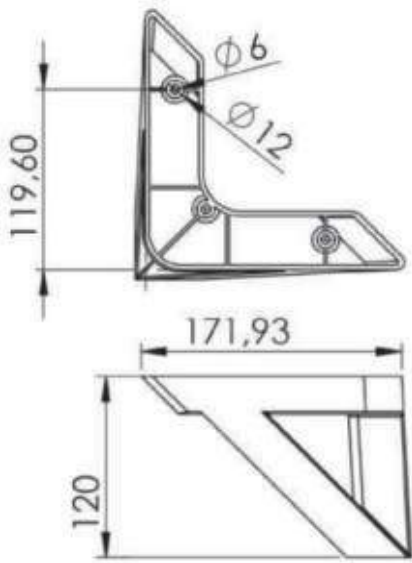

AL 45 A



AL 45 B

## AL 46 (14 cm)

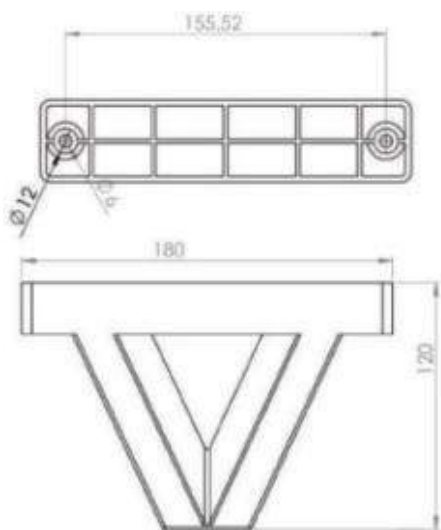

AL 46 A



AL 46 B

## AL 47 (16 cm)

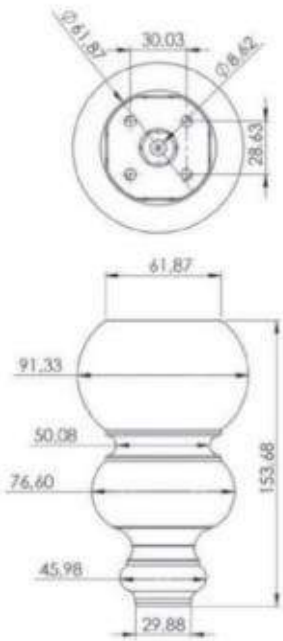

AL 47 A



AL 47 B



AL 47 C

## AL 48 (20cm)

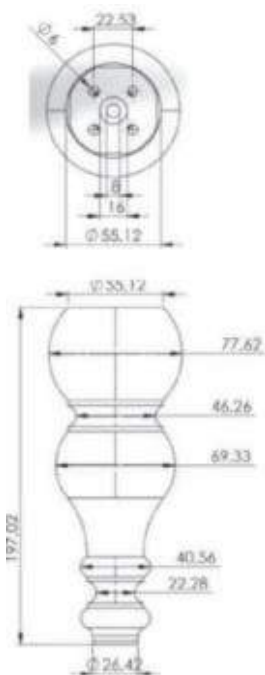

AL 48 A



AL 48 B



AL 48 C

## AL 49 (10 cm)

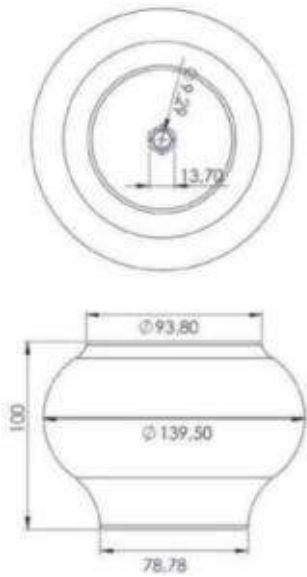

AL 49 A



AL 49 B



AL 49 C

## AL 50 (18cm)

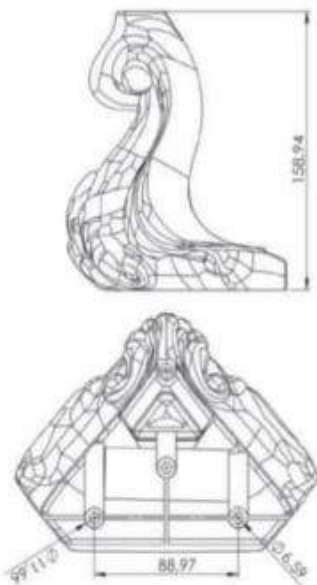

AL 50 A



AL 50 B



AL 50 C

## AL 51 (10 cm)

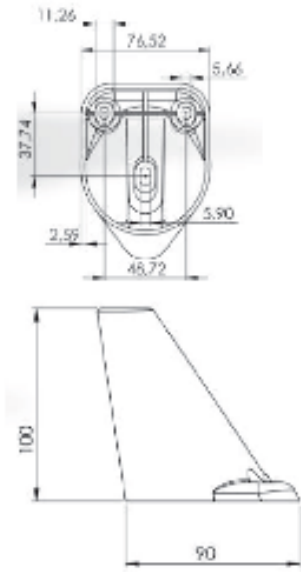

AL 51 A

## AL 52 (18cm)

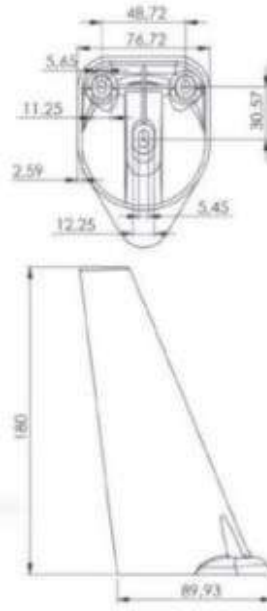

AL 52 A

## AL 53 (16x16cm)

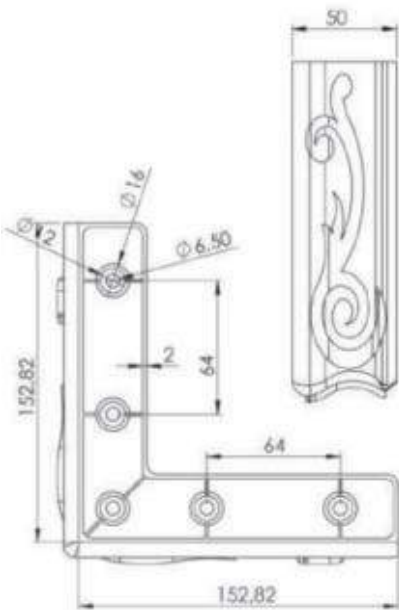

AL 53 A



AL 53 B

## AL 54 (10 cm)

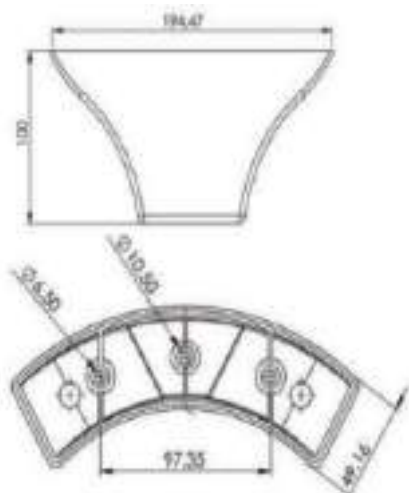

AL 54 A



AL 54 B

## AL 55 (14 cm)

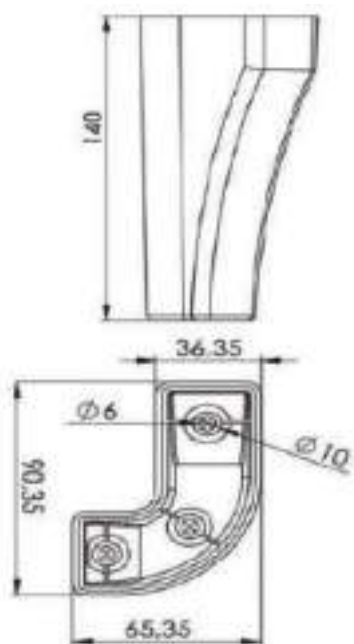

AL 55 A



AL 55 B

## AL 56 (12cm)

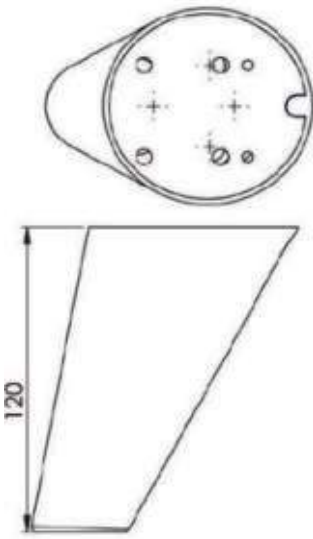

AL 56 A



AL 56 B

## AL 57 (10cm)

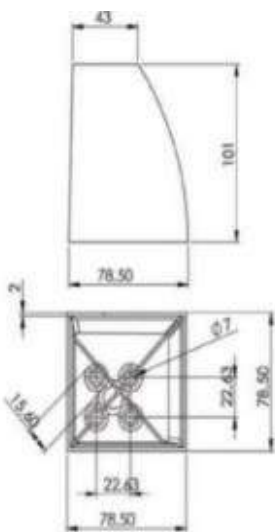

AL 57 A



AL 57 B



AL 57 C

## AL 58 (11 cm)

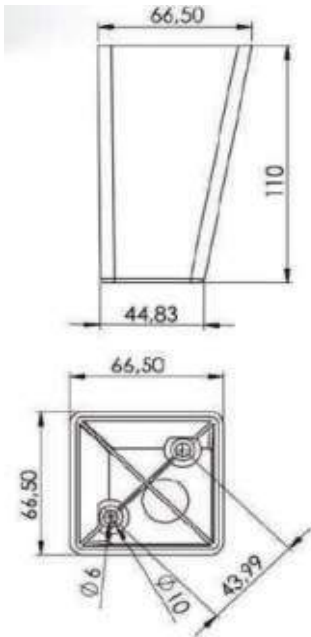

AL 58 A



AL 58 B



AL 58 C

## AL 59 (12cm)

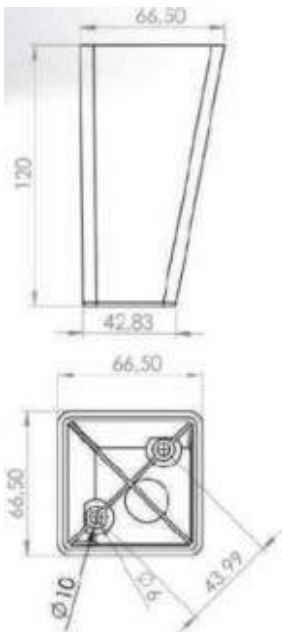

AL 59 A



AL 59 B



AL 59 C

## AL 60 (14 cm)

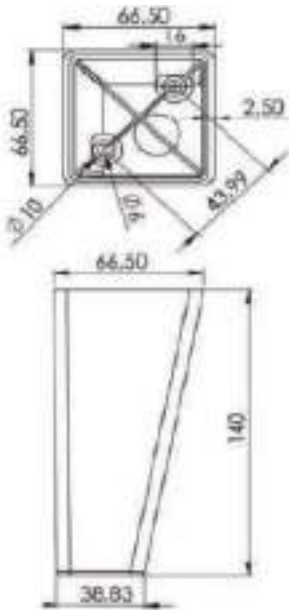

AL 60 A



AL 60 B



AL 60 C

## AL 61 (16cm)

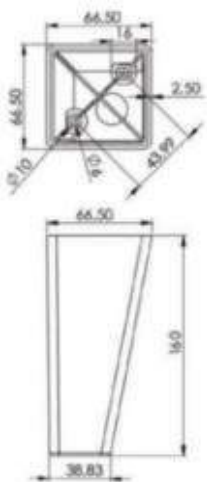

AL 61 A



AL 61 B

## AL 62 (18 cm)

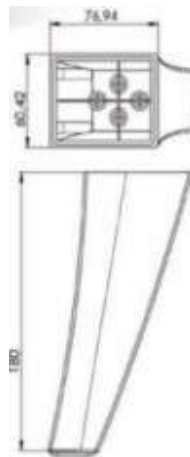

AL 62 A



AL 62 B

## AL 63 (12 cm)

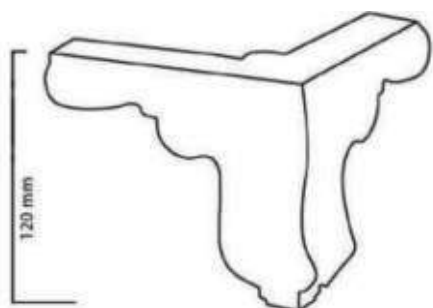

AL 63 A



AL 63 B

## AL 64 (14 cm)

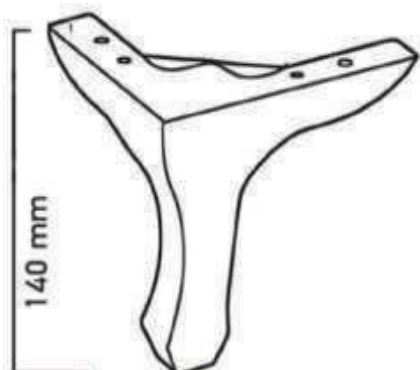

AL 64 A



AL 64 B

## AL 65 (14x14x4 cm)



AL 65 A

## AL 66 (18x18x5 cm)

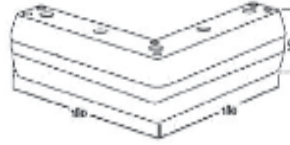

AL 66 A

## AL 67 (14 cm)

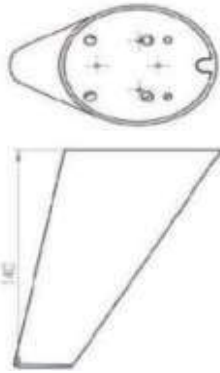

AL 67 A



AL 67 B

## AL 68 (14 cm)

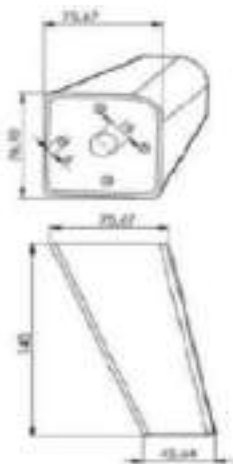

AL 68 A



AL 68 B



AL 68 C

## AL 69 (12 cm)

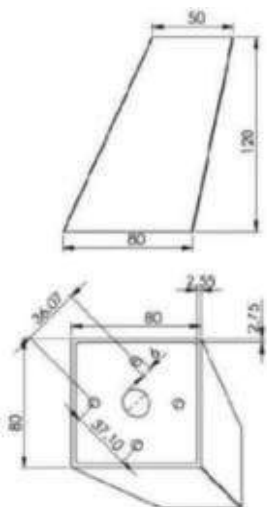

AL 69 A

AL 69 B

AL 69 C

## AL 70 (9 cm)

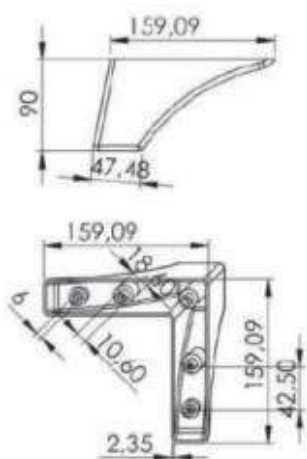

AL 70 A

AL 70 B

AL 70 C

AL 71 (22x12x5 cm)

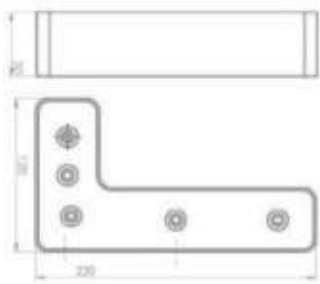

AL 71 A

AL 72 (18x18x5 cm)

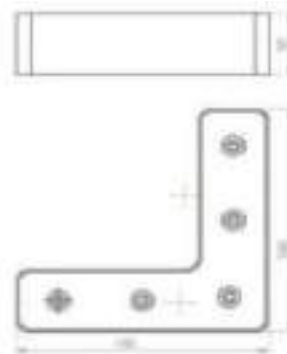

AL 72 A

AL 73 (14x14x4 cm)



AL 73 A

AL 74 (18x18x4 cm)

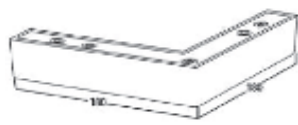

AL 74 A

AL 75 (16x11x6 cm)

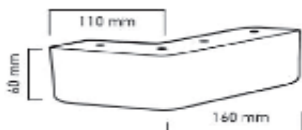

AL 75 A

AL 76 (25x12x5 cm)

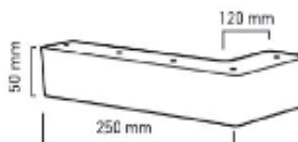

AL 76 A

## AL 77 (83x83 cm)

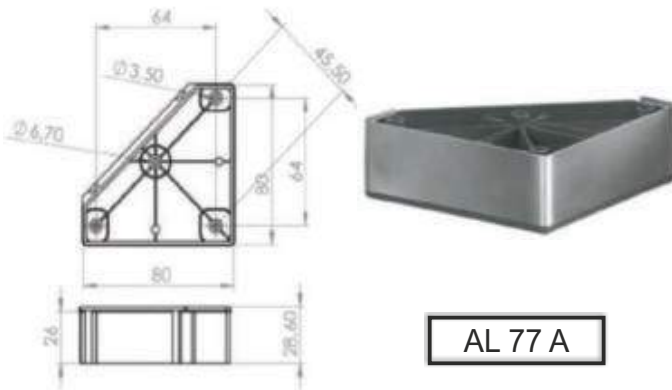

AL 77 A

## AL 78 (120x120 cm)

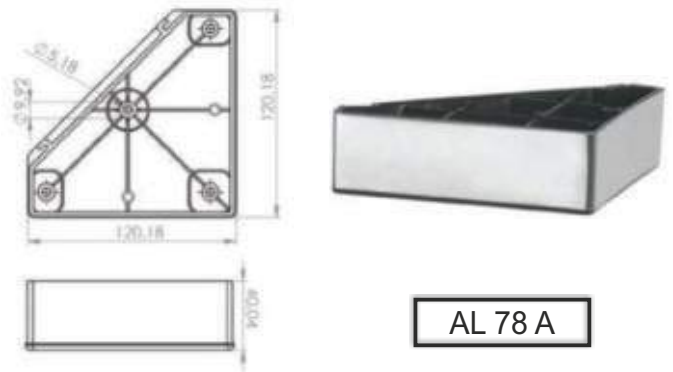

AL 78 A

## AL 79 (70x130 cm)

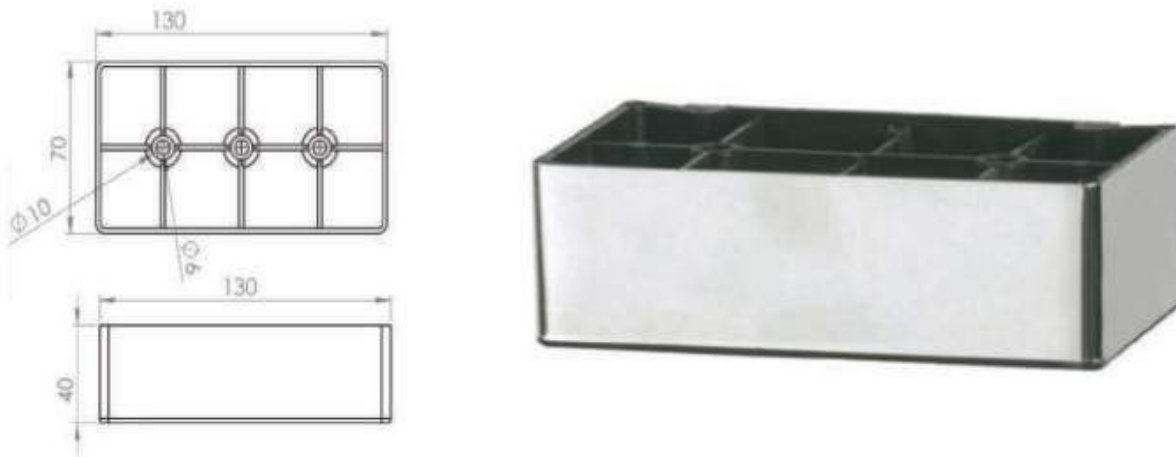

AL 79 A

## AL 80 (8 cm)



AL 80 A

AL 80 B

AL 80 C

## AL 81 (10 cm)

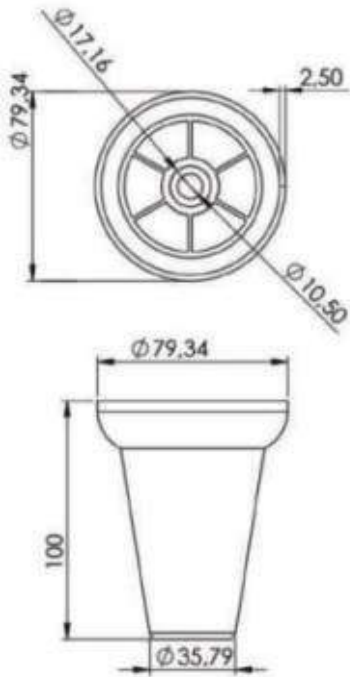

AL 81 A



AL 81 B

## AL 82 (12 cm)

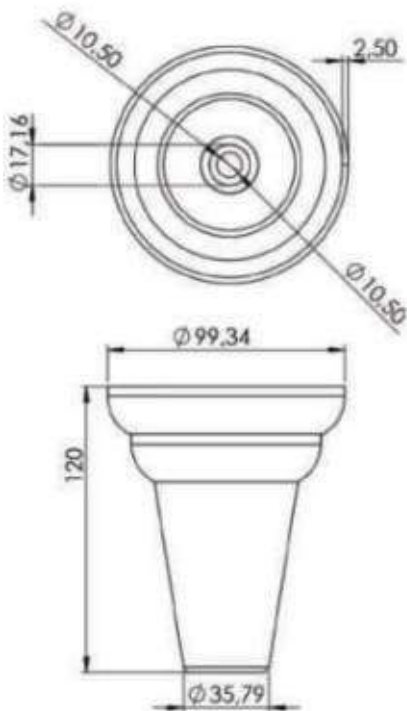

AL 82 A



AL 82 B

## AL 83 (14 cm)



AL 83 A



AL 84 B

## AL 84 (6,5 cm)



AL 84 A



AL 84 B



AL 84 C

## AL 85 (15 cm)

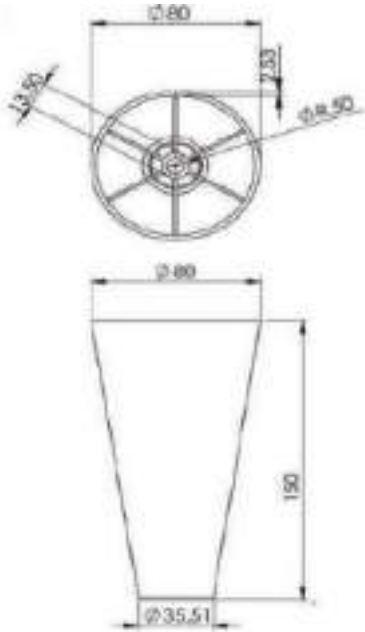

AL 85 A



AL 85 B



AL 85 C

## AL 86 (15 cm)

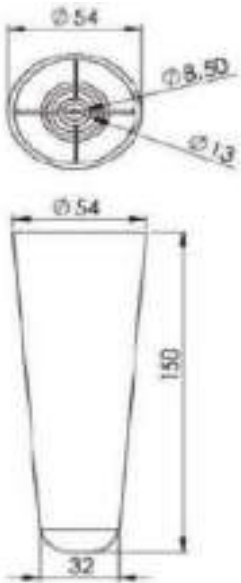

AL 86 A



AL 86 B



AL 86 C

## AL 87 (8 cm)

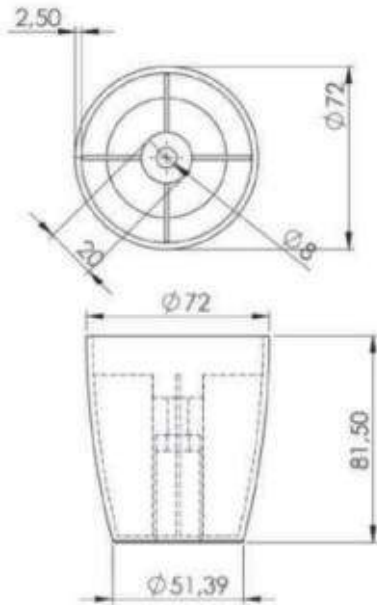

AL 87 A

AL 87 B

AL 87 C

## AL 88 (7,5 cm)

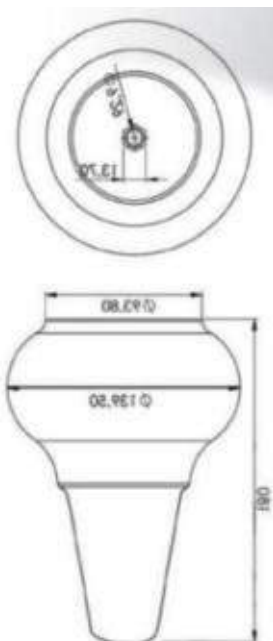

AL 88 A

AL 88 B

AL 88 C

AL 89 (8,5 cm)



AL 89 A

AL 90 (19,5 cm)



AL 90 A

AL 91 (18 cm)



AL 91 A



AL 91 B

AL 92 (10 cm)



AL 92 A



AL 92 B

AL 93 (9 cm)



AL 93 A

AL 94 (10 cm)

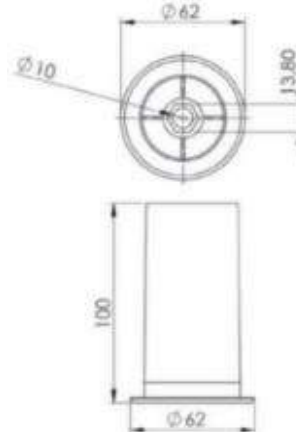

AL 94 A

AL 95 (11 cm)

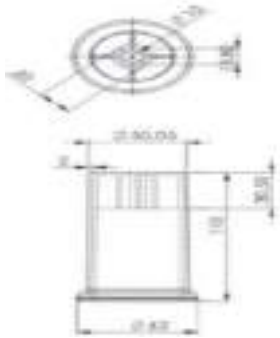

AL 95 A

AL 96 (13,8 cm)

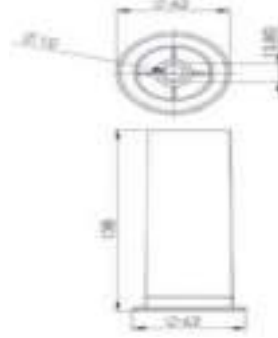

AL 96 A

AL 97 (9,5 cm)



AL 97 A



AL 97 B

AL 98 (13 cm)



AL 98 A



AL 98 B

AL 99 (16 cm)



AL 99 A



AL 99 B

AL 100 (17 cm)

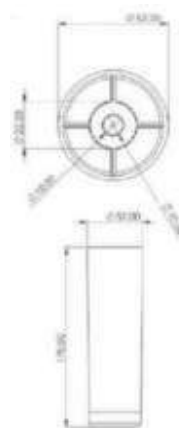

AL 100 A



AL 100 B

AL 101 (18 cm)

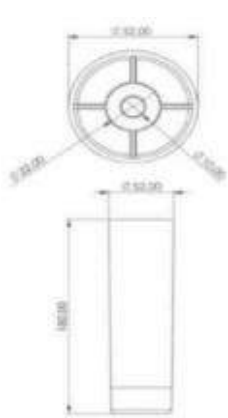

AL 101 A



AL 101 B

AL 102 (9 cm)

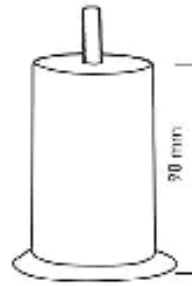

AL 102 A

AL 103 (10 cm)

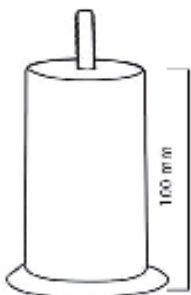

AL 103 A

AL 104 (11 cm)

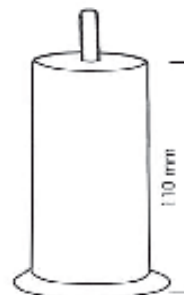

AL 104 A

AL 105 (13,8 cm)



AL 105 A

AL 106 (9,5 cm)



AL 106 A

AL 107 (10,3 cm)



AL 107 A

AL 108 (10,9 cm)



AL 108 A

AL 109 (11,5 cm)



AL 109 A

AL 110 (13,5 cm)



AL 110 A

AL 111 (14,5 cm)



AL 111 A

AL 112 (12x15 cm)



AL 112 A



AL 112 B



AL 112 C



AL 112 D



AL 112 E

## AL 113 (20 cm)



AL 113 A



AL 113 B



AL 113 C



AL 113 D



AL 113 E

## AL 114 (16 cm)



AL 114 A



AL 114 B



AL 114 C



AL 114 D



AL 114 E

## AL 115 (20 cm)



AL 115 A



AL 115 B



AL 115 C



AL 115 D



AL 112 E

## AL 116 (18 cm)



AL 116 A



AL 116 B



AL 116 C



AL 116 D

## AL 117 (10 cm)



AL 117 A



AL 117 B



AL 117 C



AL 117 D

## AL 118 (10 cm)



AL 118 A



AL 118 B



AL 118 C



AL 118 D

## AL 119 (10 cm)



AL 119 A



AL 119 B



AL 119 C



AL 119 D

## AL 120 (10 cm)



AL 120 A



AL 120 B



AL 120 C



AL 120 D



AL 120 E



AL 120 F

## AL 121 (8 cm)



AL 121 A



AL 121 B



AL 121 C



AL 121 D



AL 121 E



AL 121 F

AL 122 (15 cm)



AL 122 A

AL 122 B

AL 122 C

AL 123 (15 cm)



AL 123 A

AL 123 B

AL 123 C

AL 124 (9 cm)



AL 124 A

AL 124 B

AL 124 C

AL 124 D

AL 125 (10 cm)



AL 125 A

AL 125 B

AL 125 C

AL 126 (7,5 cm)



AL 126 A

AL 126 B

AL 127 (10 cm)



AL 127 A



AL 127 B

AL 128 (10 cm)



AL 128 A



AL 128 B



AL 128 C

AL 129



AL 129 A



AL 129 B



AL 129 C



AL 129 D



AL 129 E

AL 130



AL 130 A



AL 130 B



AL 130 C



AL 130 D



## METAL LEG

ML 1616



<b>Colour:</b>	Chrome
<b>H:</b>	40x120mm
<b>Q:</b>	42mm
<b>Material:</b>	Metal

ML 1617



<b>Colour:</b>	Chrome
<b>H:</b>	40x120mm
<b>Q:</b>	42mm
<b>Material:</b>	Metal

ML 1618



<b>Colour:</b>	Painted
<b>H:</b>	100mm
<b>Q:</b>	2,50mm
<b>Material:</b>	Metal

ML 1619



<b>Colour:</b>	Chrome
<b>H:</b>	100mm
<b>Q:</b>	2,50mm
<b>Material:</b>	Metal

ML 1620



<b>Colour:</b>	Chrome
<b>H:</b>	36mm
<b>L:</b>	150mm
<b>Q:</b>	32mm
<b>Material:</b>	Metal

ML 1621



<b>Colour:</b>	Chrome
<b>H:</b>	36mm
<b>L:</b>	150mm
<b>L1:</b>	150mm
<b>Q:</b>	32mm
<b>Material:</b>	Metal

ML 1622



<b>Colour:</b>	Painted
<b>H:</b>	150mm
<b>Q:</b>	25x50mm
<b>Material:</b>	Tube

ML 1623



<b>Colour:</b>	Chrome
<b>H:</b>	90mm
<b>L:</b>	180mm
<b>Q:</b>	20x20mm
<b>Material:</b>	Metal

ML 1624



<b>Colour:</b>	Chrome
<b>H:</b>	100mm
<b>L:</b>	360mm
<b>Q:</b>	20x40x1.2mm
<b>Material:</b>	Metal

ML 1625



<b>Colour:</b>	Chrome
<b>H:</b>	45mm
<b>L:</b>	150mm
<b>L1:</b>	150mm
<b>Q:</b>	40x40x1.2mm
<b>Material:</b>	Metal

ML 1626



<b>Colour:</b>	Chrome
<b>H:</b>	180mm
<b>Q:</b>	25mm
<b>Material:</b>	Tube

ML 1627



<b>Colour:</b>	Chrome
<b>H:</b>	180mm
<b>Q:</b>	20x40mm
<b>Material:</b>	Profile

ML 1628



<b>Colour:</b>	Painted
<b>H:</b>	180mm
<b>Q:</b>	25mm
<b>Material:</b>	Tube

ML 1629



<b>Colour:</b>	Antique
<b>H:</b>	180mm
<b>Q:</b>	25mm
<b>Material:</b>	Tube

ML 1630



<b>Colour:</b>	Chrome
<b>H:</b>	105mm
<b>L:</b>	140mm
<b>L1:</b>	140mm
<b>Q:</b>	2mm
<b>Material:</b>	Metal

ML 1631



<b>Colour:</b>	Chrome
<b>H:</b>	100mm
<b>L:</b>	100mm
<b>L1:</b>	100mm
<b>Q:</b>	2mm
<b>Material:</b>	Metal

ML 1632



<b>Colour:</b>	Chrome
<b>H:</b>	125mm
<b>L:</b>	100mm
<b>L1:</b>	100mm
<b>Q:</b>	3mm
<b>Material:</b>	Metal

ML 1633



<b>Colour:</b>	Chrome
<b>H:</b>	125mm
<b>L:</b>	160mm
<b>L1:</b>	160mm
<b>Q:</b>	2mm
<b>Material:</b>	Metal

ML 1634



<b>Colour :</b>	Satine
<b>H:</b>	40mm
<b>L:</b>	150mm
<b>L1:</b>	150mm
<b>Q:</b>	2mm
<b>Material:</b>	Metal

ML 1635



<b>Colour :</b>	Crome
<b>H:</b>	40mm
<b>L:</b>	150mm
<b>L1:</b>	150mm
<b>Q:</b>	2mm
<b>Material:</b>	Metal

ML 1636



<b>Colour :</b>	Chrome
<b>H:</b>	40mm
<b>L:</b>	150mm
<b>L1:</b>	150mm
<b>Q:</b>	2mm
<b>Material:</b>	Metal

ML 1637



<b>Colour :</b>	Crome
<b>H:</b>	120mm
<b>L:</b>	100mm
<b>L1:</b>	100mm
<b>Q:</b>	2mm
<b>Material:</b>	Metal

ML 1638



<b>Colour :</b>	Chrome
<b>H:</b>	120mm
<b>L :</b>	135mm
<b>L1 :</b>	135mm
<b>Q :</b>	2mm
<b>Material:</b>	Metal

ML 1639



<b>Colour :</b>	Chrome
<b>H:</b>	135mm
<b>L :</b>	100mm
<b>L1 :</b>	100mm
<b>Q :</b>	2mm
<b>Material:</b>	Metal

ML 1640



<b>Colour:</b>	Chrome
<b>H:</b>	70mm
<b>L:</b>	215mm
<b>L1:</b>	100mm
<b>Q:</b>	2mm
<b>Material:</b>	Metal

ML 1641



<b>Colour:</b>	Chrome
<b>H:</b>	220mm
<b>Q:</b>	2mm
<b>Material:</b>	Metal

ML 1642



<b>Colour :</b>	Copper
<b>H:</b>	180mm
<b>Q:</b>	2mm
<b>Material:</b>	Metal

ML 1643



<b>Colour :</b>	Painted
<b>H:</b>	120mm
<b>Q:</b>	2mm
<b>Material:</b>	Metal

ML 1644



<b>Colour :</b>	Antique
<b>H:</b>	180mm
<b>Q:</b>	2mm
<b>Material:</b>	Metal

ML 1645



<b>Colour :</b>	Chrome
<b>H:</b>	90mm
<b>L:</b>	70mm
<b>Q:</b>	4mm
<b>Material:</b>	Metal

ML 1646



<b>Colour :</b>	Chrome
<b>H:</b>	100mm
<b>L :</b>	120mm
<b>Q :</b>	50x8mm
<b>Material:</b>	Metal

ML 1647



<b>Colour :</b>	Chrome
<b>H:</b>	125mm
<b>L :</b>	100mm
<b>Q :</b>	12mm
<b>Material:</b>	Metal

ML 1648



<b>Colour:</b>	Chrome
<b>H:</b>	545mm
<b>Q:</b>	3mm
<b>Material:</b>	Metal

ML 1649



<b>Colour:</b>	Chrome
<b>H:</b>	100mm
<b>L:</b>	900mm
<b>Q:</b>	5mm
<b>Material:</b>	Metal

ML 1650



<b>Colour:</b>	Chrome
<b>H:</b>	310mm
<b>L:</b>	1000mm
<b>Q:</b>	8mm
<b>Material:</b>	Metal

ML 1651



<b>Colour:</b>	Chrome
<b>H:</b>	140mm
<b>Q:</b>	5mm
<b>Material:</b>	Metal

ML 1652



<b>Colour:</b>	Chrome
<b>H:</b>	170mm
<b>Q:</b>	10mm
<b>Material:</b>	Metal

ML 1653



<b>Colour:</b>	Gold
<b>H:</b>	170mm
<b>Q:</b>	10mm
<b>Material:</b>	Metal

ML 1654



<b>Colour:</b>	Satine
<b>H:</b>	170mm
<b>Q:</b>	10mm
<b>Material:</b>	Metal

ML 1655



<b>Colour:</b>	Chrome
<b>H:</b>	145mm
<b>Q:</b>	3mm
<b>Material:</b>	Metal

ML 1656



<b>Colour:</b>	Painted
<b>H:</b>	145mm
<b>Q:</b>	3mm
<b>Material:</b>	Metal

ML 1657



<b>Colour:</b>	Chrome
<b>H:</b>	130mm
<b>L:</b>	850mm
<b>Q:</b>	8mm
<b>Material:</b>	Metal

ML 1658



<b>Colour:</b>	Chrone
<b>H:</b>	110mm
<b>L:</b>	220mm
<b>Q:</b>	6mm
<b>Material:</b>	Metal

ML 1659



<b>Colour:</b>	Chrome
<b>H:</b>	150mm
<b>L:</b>	50mm
<b>L1:</b>	900mm
<b>Q:</b>	8mm
<b>Material:</b>	Metal

ML 1660



<b>Colour:</b>	Satine
<b>H:</b>	160mm
<b>Q:</b>	8mm
<b>Material:</b>	Metal

ML 1661



<b>Colour:</b>	Painted
<b>H:</b>	160mm
<b>Q:</b>	15mm
<b>Material:</b>	Metal

ML 1662



<b>Colour:</b>	Painted
<b>H:</b>	160mm
<b>Q:</b>	10mm
<b>Material:</b>	Metal

ML 1663



<b>Colour:</b>	Gold
<b>H:</b>	240mm
<b>Q:</b>	10mm
<b>Material:</b>	Metal

ML 1664



<b>Colour:</b>	Painted
<b>H:</b>	730mm
<b>Q:</b>	12mm
<b>Material:</b>	Metal

ML 1665



<b>Colour:</b>	Painted
<b>H:</b>	180mm
<b>Q:</b>	10mm
<b>Material:</b>	Metal

ML 1666



<b>Colour:</b>	Copper
<b>H:</b>	120mm
<b>L:</b>	60mm
<b>Q:</b>	8mm
<b>Material:</b>	Metal

ML 1667



<b>Colour:</b>	Chrome
<b>H:</b>	120mm
<b>L:</b>	60mm
<b>Q:</b>	8mm
<b>Material:</b>	Metal

ML 1668



<b>Colour:</b>	Chrome
<b>H:</b>	10mm
<b>L:</b>	70mm
<b>Q:</b>	1,2mm
<b>Material:</b>	Metal

ML 1669



<b>Colour:</b>	Chrome
<b>H:</b>	180mm
<b>Q:</b>	10mm
<b>Material:</b>	Metal

ML 1670



<b>Colour:</b>	Chrome
<b>H:</b>	150mm
<b>L:</b>	880mm
<b>Q:</b>	10mm
<b>Material:</b>	Metal

ML 1671



<b>Colour:</b>	Painted
<b>H:</b>	150mm
<b>L:</b>	880mm
<b>Q:</b>	10mm
<b>Material:</b>	Metal

ML 1672



<b>Colour:</b>	Painted
<b>H:</b>	160mm
<b>L:</b>	800mm
<b>Q:</b>	10mm
<b>Material:</b>	Metal

ML 1673



<b>Colour:</b>	Chrome
<b>H:</b>	120mm
<b>L:</b>	800mm
<b>Q:</b>	50x8mm
<b>Material:</b>	Metal

ML 1674



<b>Colour:</b>	Painted
<b>H:</b>	220mm
<b>Q:</b>	8mm
<b>Material:</b>	Metal

ML 1675



<b>Colour:</b>	Chrome
<b>H:</b>	170/170/170mm
<b>L:</b>	1000/1150/2000mm
<b>Q:</b>	20x40x1.2mm
<b>Material:</b>	Elips Metal

ML 1676



<b>Colour:</b>	Painted
<b>H:</b>	120mm
<b>L:</b>	750mm
<b>Q:</b>	20x40mm
<b>Material:</b>	Elips Metal

ML 1677



<b>Colour:</b>	Gold
<b>H:</b>	150mm
<b>L:</b>	750mm
<b>Q:</b>	20x40mm
<b>Material:</b>	Profile

ML 1678



<b>Colour:</b>	Chrome
<b>H:</b>	630/580/530mm
<b>L:</b>	400/340/280mm
<b>L1:</b>	390/370/350mm
<b>Q:</b>	15x15x12mm
<b>Material:</b>	Metal

ML 1679



<b>Colour:</b>	Chrome
<b>H:</b>	600/545/490mm
<b>L:</b>	550/500/450mm
<b>L1:</b>	410/375/350mm
<b>Q:</b>	15x15x12mm
<b>Material:</b>	Metal

ML 1680



<b>Colour:</b>	Chrome
<b>H:</b>	599/550/450mm
<b>L:</b>	490/425/365mm
<b>L1:</b>	410/380/350mm
<b>Q:</b>	15x15x12mm
<b>Material:</b>	Metal

ML 1681



<b>Colour:</b>	Gold
<b>H:</b>	450mm
<b>L:</b>	700mm
<b>Q:</b>	2mm
<b>Material:</b>	Metal

ML 1682



<b>Colour:</b>	Gold
<b>H:</b>	550mm
<b>L:</b>	450mm
<b>Q:</b>	2mm
<b>Material:</b>	Metal

ML 1683



<b>Colour :</b>	Painted
<b>H:</b>	400mm
<b>L :</b>	680mm
<b>Q :</b>	6mm
<b>Material:</b>	Full Tube

ML 1684



<b>Colour:</b>	Painted
<b>H:</b>	550mm
<b>L:</b>	475mm
<b>Q:</b>	6mm
<b>Material:</b>	Full Tube

ML 1685



<b>Colour:</b>	Copper
<b>H:</b>	710mm
<b>Q:</b>	60mm
<b>Material:</b>	Tube

ML 1686



<b>Colour:</b>	Chrome
<b>H:</b>	710mm
<b>Q:</b>	60mm
<b>Material:</b>	Tube

ML 1687



<b>Colour:</b>	Painted
<b>H:</b>	710mm
<b>Q:</b>	60mm
<b>Material:</b>	Tube

ML 1688



Colour:	Gold
H:	260mm
Q:	10mm
Material:	Metal

ML 1689



Colour:	Satine
H:	260mm
Material:	Aluminum

ML 1690



Colour:	Painted
H:	260mm
Q:	10mm
Material:	Metal

ML 1691



Colour :	Painted
H:	260mm
Material:	Aluminum

ML 1692



Colour:	Chrome
H:	170mm
Q:	32mm
Material:	Metal

ML 1693



Colour :	Chrome
H:	46mm
L :	200mm
Q :	32mm
Material:	Metal

ML 1694



Colour:	Chrome
H:	55mm
L:	150mm
L1:	50mm
Q:	51mm
Material:	Metal

ML 1695



Colour:	Gold
H:	260mm
Q:	51mm
Material:	Metal

ML 1696



<b>Colour:</b>	Satine
<b>H:</b>	150mm
<b>Q:</b>	16mm
<b>Material:</b>	Tube

ML 1697



<b>Colour:</b>	Painted
<b>H:</b>	180mm
<b>Q:</b>	32mm
<b>Material:</b>	Tube

ML 1698



<b>Colour:</b>	Satine
<b>H:</b>	150mm
<b>Q:</b>	32mm
<b>Material:</b>	Tube

ML 1699



<b>Colour:</b>	Chrome
<b>H:</b>	650mm
<b>L:</b>	430mm
<b>Q:</b>	40x40x1.2mm
<b>Material:</b>	Metal

ML 1700



<b>Colour:</b>	Chrome
<b>H:</b>	130mm
<b>L:</b>	750mm
<b>Q:</b>	40x40x1.2mm
<b>Material:</b>	Metal

ML 1701



<b>Colour:</b>	Painted
<b>H:</b>	150mm
<b>Q:</b>	20x40mm
<b>Material:</b>	Profile

ML 1702



<b>Colour:</b>	Chrome
<b>H:</b>	80mm
<b>L:</b>	80mm
<b>L1:</b>	80mm
<b>Q:</b>	2mm
<b>Material:</b>	Metal

ML 1703



<b>Colour :</b>	Chrome
<b>H:</b>	70mm
<b>L :</b>	235mm
<b>Q :</b>	2mm
<b>Material:</b>	Metal

ML 1704



Colour:	Chrome
H:	45mm
L:	150mm
L1:	150mm
Q:	2mm
Material:	Metal

ML 1705



Colour:	Chrome
H:	120mm
L:	110mm
L1:	110mm
Q:	2mm
Material:	Metal

ML 1706



Colour:	Painted
H:	120mm
L:	110mm
L1:	110mm
Q:	2mm
Material:	Metal

ML 1707



Colour:	Chrome
H:	180mm
Q:	2mm
Material:	Metal

ML 1708



Colour:	Painted
H:	180mm
Q:	2mm
Material:	Metal

ML 1709



Colour:	Painted
H:	180mm
Q:	20x20mm
Material:	Profile

ML 1710



Colour:	Chrome
H:	80mm
L:	100mm
Q:	5mm
Material:	Sheet Metal

ML 1711



Colour :	Chrome
H:	70mm
L :	90mm
Q :	4mm
Material:	Sheet Metal

ML 1712



<b>Colour:</b>	Chrome
<b>H:</b>	100mm
<b>L:</b>	900mm
<b>Q:</b>	50x8mm
<b>Material:</b>	Metal

ML 1713



<b>Colour:</b>	Chrome
<b>H:</b>	105mm
<b>L:</b>	40mm
<b>L1:</b>	200mm
<b>Q:</b>	8mm
<b>Material:</b>	Metal

ML 1714



<b>Colour:</b>	Chrome
<b>H:</b>	95mm
<b>L:</b>	60mm
<b>Q:</b>	5mm
<b>Material:</b>	Sheet Metal

ML 1715



<b>Colour:</b>	Chrome
<b>H:</b>	630/580/530mm
<b>L:</b>	400/370/350mm
<b>L1:</b>	400/345/285mm
<b>Q:</b>	12mm
<b>Material:</b>	Metal

ML 1716



<b>Colour:</b>	Chrome
<b>H:</b>	450/500/550mm
<b>L:</b>	350/400/450mm
<b>L1:</b>	350/400/450mm
<b>Q:</b>	10x10x1.2mm
<b>Material:</b>	Metal

ML 1717



<b>Colour:</b>	Chrome
<b>H:</b>	400mm
<b>Q:</b>	12mm
<b>Material:</b>	Metal

ML 1718



<b>Colour:</b>	Chrome
<b>H:</b>	630mm
<b>L:</b>	400mm
<b>L1:</b>	400mm
<b>Q:</b>	12mm
<b>Material:</b>	Metal

ML 1719



<b>Colour:</b>	Antique Brass
<b>H:</b>	600mm
<b>L:</b>	500mm
<b>L1:</b>	16mm
<b>Q:</b>	5mm
<b>Material:</b>	Metal

ML 1720



<b>Colour:</b>	Painted
<b>H:</b>	600mm
<b>L:</b>	500mm
<b>L1:</b>	16mm
<b>Q:</b>	5mm
<b>Material:</b>	Metal

ML 1721



<b>Colour:</b>	Chrome
<b>H:</b>	400mm
<b>Q:</b>	15x15mm
<b>Material:</b>	Profile

ML 1722



<b>Colour:</b>	Chrome
<b>H:</b>	725mm
<b>L:</b>	400mm
<b>Q:</b>	76mm
<b>Material:</b>	Stainles Metal

ML 1723



<b>Colour:</b>	Chrome
<b>H:</b>	725mm
<b>L:</b>	400x400mm
<b>Q:</b>	70x70mm
<b>Material:</b>	Stainles Metal

ML 1724



<b>Colour:</b>	Chrome
<b>H:</b>	710mm
<b>Material:</b>	D Profile

ML 1725



<b>Colour:</b>	Satine
<b>H:</b>	710mm
<b>Material:</b>	D Profile

ML 1726



<b>Colour:</b>	Chrome
<b>H:</b>	710mm
<b>Material:</b>	Triangle Profile



# MECHANISM



SMEC 1616



SMEC 1617



SMEC 1618



SMEC 1619



SMEC 1620



SMEC 1621



SMEC 1622



SMEC 1623



SMEC 1624



SMEC 1625



SMEC 1626



SMEC 1627



SMEC 1628



SMEC 1629



SMEC 1630



SMEC 1631

# MEC 1616

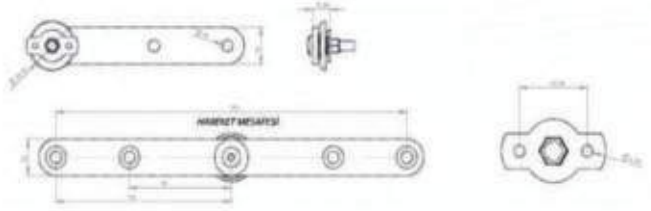

# MEC 1617

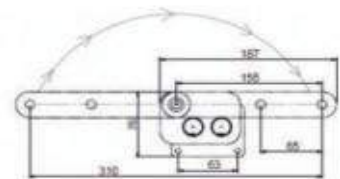

## MEC 1618



## MEC 1619





# MEC 1622



# MEC 1623



## MEC 1624

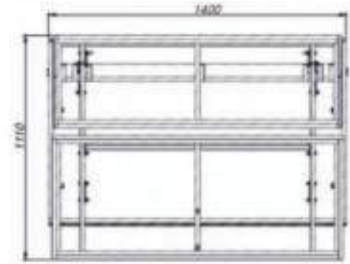
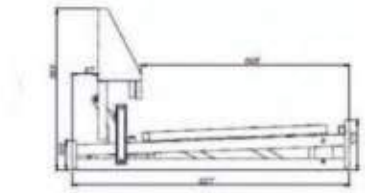

## MEC 1625

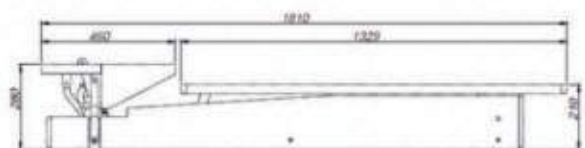
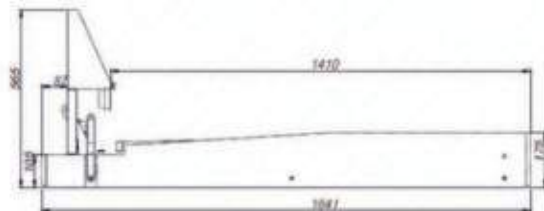
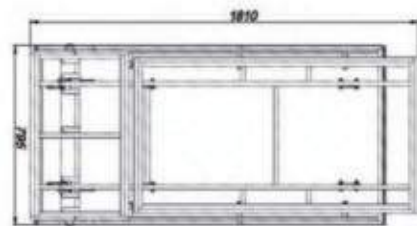

# MEC 1626



# MEC 1627



## MEC 1628



## MEC 1629



# MEC 1630



# MEC 1631



## MEC 1632



## MEC 1633



# MEC 1634



# MEC 1635



## MEC 1636



✓ MEC 1616 can be produced in different sizes too.



# ARGON WELDING WIRE



## Argon Welding Wire



ITEM CODE

AW 1616



**STAPLE**

STAPLE

80 SERIES



ITEM CODE	DIMENSION	STICK IN A POCKET	STICK PCS	BOX PCS	BOX KG	PRODUCT
STP 8004	80X04	1.024	150	153.600	11,11	Staples
STP 8006	80X06	704	150	105.600	9,44	Staples
STP 8008	80X08	544	150	81.600	8,60	Staples
STP 8010	80X10	448	150	67.200	8,02	Staples
STP 8012	80X12	384	150	57.600	6,86	Staples
STP 8014	80X14	320	150	48.000	7,38	Staples
STP 8016	80X16	288	150	43.200	6,92	Staples
STP 8018	80X18	256	150	38.400	5,58	Staples
STP 8020	80X20	224	150	33.600	5,68	Staples
STP 8022	80X22	192	150	28.800	5,38	Staples

90 SERIES



ITEM CODE	DIMENSION	STICK IN A POCKET	STICK PCS	BOX PCS	BOX KG	PRODUCT
STP 9025	90X25	196	100	19.600	8,78	Staples
STP 9030	90X30	168	100	16.800	9,36	Staples
STP 9035	90X35	140	100	14.000	9,06	Staples
STP 9040	90X40	140	100	14.000	10,32	Staples

STAPLE

92 SERIES

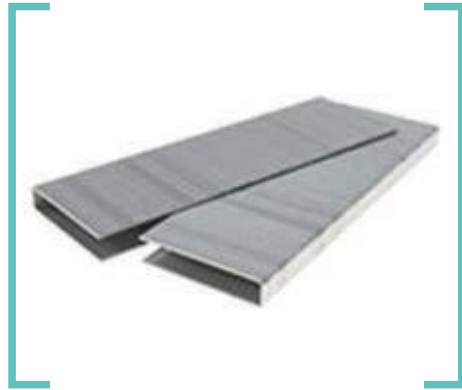

ITEM CODE	DIMENSION	STICK IN A POCKET	STICK PCS	BOX PCS	BOX KG	PRODUCT
STP 9025	90X25	196	100	19.600	8,78	Staples
<b>STP 9030</b>	90X30	<b>168</b>	100	<b>16.800</b>	<b>9,36</b>	Staples
STP 9035	90X35	140	100	14.000	9,06	Staples
<b>STP 9040</b>	90X40	<b>140</b>	100	<b>14.000</b>	<b>10,32</b>	Staples

100 SERIES



ITEM CODE	DIMENSION	STICK IN A POCKET	STICK PCS	BOX PCS	BOX KG	PRODUCT
STP10020	100X20	144	75	10.800	6,80	Staples
<b>STP 10025</b>	100X25	<b>128</b>	75	<b>9.600</b>	<b>7,30</b>	Staples
STP 10030	100X30	96	75	7.200	6,44	Staples
<b>STP 10032</b>	100X32	<b>96</b>	75	<b>7.200</b>	<b>6,90</b>	Staples
<b>STP 10035</b>	100X35	<b>80</b>	75	<b>6.000</b>	<b>6,22</b>	Staples
STP 10038	100X38	80	75	6.000	6,74	Staples
<b>STP 10040</b>	100X40	<b>80</b>	75	<b>6.000</b>	<b>7,10</b>	Staples
STP 10045	100X45	64	75	4.800	6,34	Staples
<b>STP10050</b>	100X50	<b>64</b>	75	<b>4.800</b>	<b>6,90</b>	Staples

## MATTRESS SERIES



ITEM CODE	DIMENSION	STICK IN A POCKET	STICK PCS	BOX PCS	BOX KG	PRODUCT
STP 8818	88X18	1.600	60	96.000	20,5	Staples



# NAILS

# Upholstery Nails



✓ Different colors available for each item above

ITEM CODE	HEAD DIAMETER	DIAMETER OF WIRE	SHANK LENGTH	PACKET PCS	BOX KG	BOX PACKET	BOX PCS	SIZE OF BOX
UN 1616	6,5	1,3	13,5	1.000	16,1	48	48.000	310X275X180
UN 1716	6,5	1,3	15	1.000	16,1	48	48.000	310X275X180
UN 1816	9,5	1,3	13,5	1.000	20,7	24	24.000	285X245X245
UN 1916	10,5	1,3	13,5	1.000	22,6	24	24.000	285X245X245
UN 2016	12,6	1,3	14	1.000	16	12	12.000	290X215X315
UN 2116	16	1,5	15	300	22,5	30	9.000	290X215X315
UN 2216	11	1,35	13	300	12	30	9.000	290X215X315
UN 2316	18	1,5	15,5	200	18,5	30	6.000	290X215X315
UN 2416	16	1,5	16	300	12	30	9.000	290X215X315
UN 2516	20	1,5	16	175	20,1	30	5.250	290X215X315
UN 2616	20	1,5	16	175	20,5	30	5.250	290X215X315
UN 2716	22	1,5	16	125	20,6	30	3.750	290X215X315

## Upholstery Nails



UN 2816



UN 2916



UN 3016

✓ Different colors available for each item above.

ITEM CODE	HEAD DIAMETER	DIAMETER OF WIRE	SHANK LENGTH	PACKET PCS	BOX KG	BOX PACKET	BOX PCS	SIZE OF BOX
UN 2816	24	1,5	16	90	14,5	30	2.700	290X215X315
UN 2916	26	1,5	16	100	13,9	30	3.000	290X215X315
UN 3016	27	1,5	16	60	12,5	30	1.800	290X215X315

## Decorative Nails

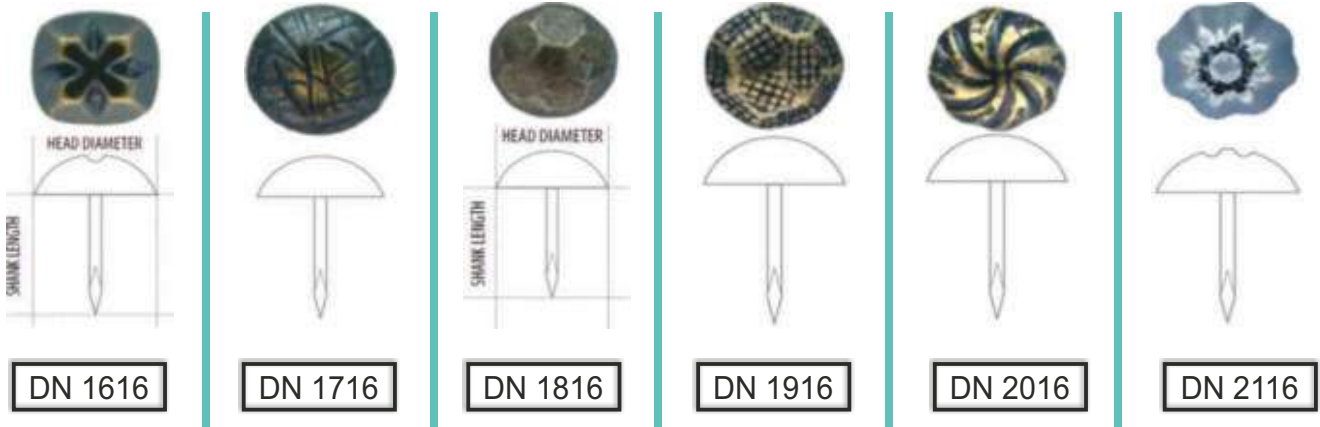

✓ Different colors available for each item above.

ITEM CODE	HEAD DIAMETER	DIAMETER OF WIRE	SHANK LENGTH	PACKET PCS	BOX KG	BOX PACKET	BOX PCS	SIZE OF BOX
DN 1616	8x8	1,3	13	1.000	18,5	24	24.000	285x245x245
DN 1716 A	10-11	1,3	13	1.000	23,3	24	24.000	285x245x245
DN 1716 B	16	1,5	16	300	22	30	9.000	290x215x315
DN 1716 C	18	1,5	16	200	18,9	30	6.000	290x215x315
DN 1816	10-11	1,3	13	1.000	23,5	24	24.000	285x245x245
DN 1916	10-11	1,35	13	1.000	23,5	24	24.000	285x245x245
DN 2016	10-11	1,3	13	1.000	23,5	24	24.000	285x245x245
DN 2116	10-11	1,3	13	1.000	23,5	24	24.000	285x245x245

## Decorative Nails



✓ Different colors available for each item above.

ITEM CODE	HEAD DIAMETER	DIAMETER OF WIRE	SHANK LENGTH	PACKET PCS	BOX KG	BOX PACKET	BOX PCS	SIZE OF BOX
DN 2216 A	10-11	1,3	13	1.000	23,3	24	24.000	285x245x245
DN 2216 B	16	1,5	16	300	22	30	9.000	290x215x315
DN 2216 C	18	1,5	16	200	18,9	30	6.000	290x215x315
DN 2316 A	10-11	1,3	13	1.000	23,3	24	24.000	285x245x245
DN 2316 B	16	1,5	16	300	22	30	9.000	290x215x315
DN 2316 C	18	1,5	18	200	18,9	30	6.000	290x215x315
DN 2416 A	10-11	1,3	13	1.000	23,3	24	24.000	285x245x245
DN 2416 B	16	1,5	16	300	22	30	9.000	290x215x315
DN 2416 C	18	1,5	18	200	18,9	30	6.000	290x215x315
DN 2516 A	10-11	1,3	13	1.000	23,3	24	24.000	285x245x245
DN 2516 B	16	1,5	16	300	22	30	9.000	290x215x315
DN 2516 C	18	1,5	18	200	18,9	30	6.000	290x215x315
DN 2616 A	10-11	1,3	13	1.000	23,3	24	24.000	285x245x245
DN 2616 B	16	1,5	16	300	22	30	9.000	290x215x315
DN 2616 C	18	1,5	18	200	18,9	30	6.000	290x215x315
DN 2716 A	16	1,5	16	300	22	30	9.000	290x215x315
DN 2716 B	18	1,5	18	200	18,9	30	6.000	290x215x315

## Decorative Nails



DN 2816

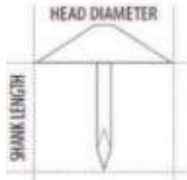

DN 2916



DN 3016



DN 3116



DN 3216



DN 3316



DN 3416



DN 3516

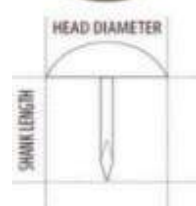

DN 3616

ITEM CODE	HEAD DIAMETER	DIAMETER OF WIRE	SHANK LENGTH	PACKET PCS	BOX KG	BOX PACKET	BOX PCS	SIZE OF BOX
DN 2816	18,5x18,5	1,5	16	125	13	30	3.750	310X275X180
DN 2916	18,5x18,5	1,5	16	125	22	30	3.750	310X275X180
DN 3016	20	1,5	16	175	19	30	5.250	290X215X315
DN 3116	20	1,5	16	175	20,1	30	5.250	290X215X315
DN 3216	14	1,3	14	300	22	30	9.000	290X215X315
DN 3316	14	1,5	16	300	15,2	30	9.000	290X215X315
DN 3416	10,5	1,3	13	1.000	22,5	24	24.000	285X245X245
DN 3516	20	1,5	16	150	20,1	30	4.500	310X275X180
DN 3616	21	1,5	19	100	17,5	30	3.000	310X275X180

## Simple Strips



SS 1616



SS 1716



SS 1816

✓ Different colors available for each item above.

ITEM CODE	HEAD DIAMETER	PACKET PCS	BOX KG	BOX PACKET	BOX PCS	SIZE OF BOX
SS 1616	12	82 (S) + 267 (N) = 1.000	19	30	30.000	535x245x235
SS 1716	12	119 (S) + 292 (N) = 1.000	19	30	30.000	380x330x235
SS 1816	12	119 (S) + 292 (N) = 1.000	19	30	30.000	380x330x235

## Nail head Strips



NHS 1616



NHS 1716



NHS 1816



NHS 1916



NHS 2016

✓ Different colors available for each item above.

ITEM CODE	HEAD DIAMETER	PACKET PCS	BOX KG	SIZE OF BOX
NHS 1616 A	9,5	250m. (S) + 6.000 (N)	12	1050x180x125
NHS 1616 B	11	250m. (S) + 6.000 (N)	15	1050x180x125
NHS 1716 A	16	125m. (S) + 2000 (N)	13,5	1050x180x125
NHS 1716 B	18	100m. (S) + 1.750 (N)	13,5	1050x180x125
NHS 1716 C	20	100m. (S) + 1.500 (N)	13,5	1050x180x125
NHS 1816	9,5	500m	17,5	1050x180x125
NHS 1916	12	125m. (S) + 2.250 (N)	12	1050x180x125
NHS 2016	12	125m. (S) + 2.250 (N)	12	1050x180x125

# Stony Nails



SN 1616



SN 1716



SN 1816



SN 1916



SN 2016

✓ Different colors available for each item above.

ITEM CODE	HEAD DIAMETER	DIAMETER OF WIRE	SHANK LENGTH	PACKET PCS	BOX KG	BOX PACKET	BOX PCS	SIZE OF BOX
SN 1616	11	1,3	13	1.000	14,1	10	10.000	365x290x200
SN 1716	17	1,5	16	500	24,4	14	7.000	365x290x200
SN 1816	21	1,5	16	500	22,4	10	5.000	365x290x200
SN 1916 A	21	1,5	11	500	19,2	8	4.000	365x290x200
SN 1916 B	21	1,5	17	500	19,2	8	4.000	365x290x200
SN 1916 C	21	1,5	20	500	19,2	8	4.000	365x290x200
SN 1916 D	21	1,5	25	500	19,2	8	4.000	365x290x200
SN 1916 E	21	1,5	30	500	19,2	8	4.000	365x290x200
SN 1916 F	21	1,5	40	500	19,2	8	4.000	365x290x200
SN 2016 A	21	1,5	11	500	19,2	8	4.000	365x290x200
SN 2016 B	21	1,5	17	500	19,2	8	4.000	365x290x200
SN 2016 C	21	1,5	20	500	19,2	8	4.000	365x290x200
SN 2016 D	21	1,5	25	500	19,2	8	4.000	365x290x200
SN 2016 E	21	1,5	30	500	19,2	8	4.000	365x290x200
SN 2016 F	21	1,5	40	500	19,2	8	4.000	365x290x200

# Printed Nails



PN 1616



PN 1716



PN 1816



PN 1916



PN 2016



PN 2116



PN 2216



PN 2316



PN 2416



PN 2516



PN 2616



PN 2716



PN 2816



PN 2916



We can print your requested desing on the loose, midi and maxi size nail according to the order quantity.

## Other Nails



ON 1616



ON 1716



ON 1816



ON 1916



ON 2016



ON 2116



ON 2216



ON 2316



ON 2416



ON 2516



ON 2616



ON 2716



ON 2816



ON 2916



ON 3016



ON 3116



ON 3216



ON 3316



ON 3416



ON 3516



ON 3616



ON 3716



ON 3816



ON 3916



ON 4016



ON 4116



ON 4216



ON 4316



ON 4416



ON 4516



ON 4616



ON 4716



ON 4816



ON 4916



ON 5016



ON 5116



ON 5216



ON 5316



ON 5416



ON 5516



ON 5616



ON 5716

## Other Nails



ON 5816



ON 5916



ON 6016



ON 6116



ON 6216



ON 6316



ON 6416



ON 6516



ON 6616



ON 6716



ON 6816



ON 6916



ON 7016



ON 7116



ON 7216



ON 7316



ON 7416



ON 7516



ON 7616



ON 7716



ON 7816



ON 7916



ON 8016



ON 8116



ON 8216



ON 8316



ON 8416



ON 8516



ON 8616



ON 8716



ON 8816



ON 8916



ON 9016



ON 9116



ON 9216



ON 9316



ON 9416



ON 9516



ON 9616



ON 9716



ON 9816



ON 9916



ON 1006



ON 1016



ON 1026



ON 1036



# **BUTTONS & CAPSULES**

## Stony Buttons

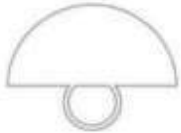

SB 1616



SB 1716



SB 1816

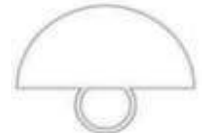

SB 1916

✓ Different colors available for each item above.

## Metal Buttons

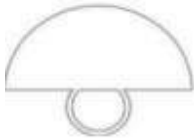

MB 1616



MB 1716

✓ Different colors available for each item above.

ITEM CODE	HEAD DIAMETER	PACKET PCS	BOX KG	BOX PACKET	BOX PCS	SIZE OF BOX
SB 1616	20	500	12,9	14	7.000	365X290X200
SB 1716	20	1.000	12,9	6	6.000	365X290X200
SB 1816	17	500	24,4	14	7.000	365X290X200
SB 1916	17	500	24,4	14	7.000	365X290X200
MB 1616 A	18	1.000	28,9	10	10.000	365X290X200
MB 1616 B	20	600	21,5	10	6.000	365X290X200
MB 1616 C	24	500	25,5	10	5.000	365X290X200
MB 1716	20	600	25,5	10	6.000	365X290X200

## Ceramic Buttons

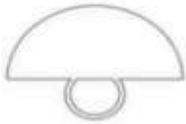

CB 1616

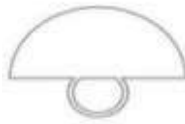

CB 1716

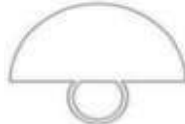

CB 1816



CB 1916

✓ Different colors available for each item above.

## Plastic Buttons

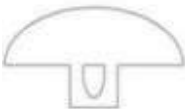

PB 1616

✓ Different colors available for each item above.

ITEM CODE	HEAD DIAMETER	PACKET PCS	BOX KG	BOX PACKET	BOX PCS	SIZE OF BOX
CB 1616	17	500	24,4	14	7.000	365X290X200
CB 1716	17	500	24,4	14	7.000	365X290X200
CB 1816	17	500	24,4	14	7.000	365X290X200
CB 1916	17	500	24,4	14	7.000	365X290X200
PB 1616 A	20	500	5	14	7.000	365X290X200
PB 1616 B	30	250	11	6	1.500	365X290X200

# Capsule Buttons



✓ CAP 1916 can be produced by aluminum and steel, no:26, 28, 30, 32, 36, 40, 44 sizes.

ITEM CODE	NO	HEAD DIAMETER	PACKET PCS	BOX KG	BOX PACKET	BOX PCS	SIZE OF BOX
CAP 1616 A	28	18	500	9,5	12	6.000	365X290X200
CAP 1616 B	32	20,5	500	8,7	12	6.000	365X290X200
CAP 1616 C	36	23	500	7,8	8	4.000	365X290X200
CAP 1716 A	26	15,5	500	13	12	6.000	365X290X200
CAP 1716 B	28	18	500	10,7	12	6.000	365X290X200
CAP 1716 C	30	19	500	9,6	12	6.000	365X290X200
CAP 1716 D	32	20,5	500	9,5	12	6.000	365X290X200
CAP 1716 E	36	23	500	8,5	8	4.000	365X290X200
CAP 1716 F	40	24	500	9,3	8	2.000	365X290X200
CAP 1716 G	44	28	500	8,2	8	2.000	365X290X200
CAP 1816	32	20,5	500	22	10	5.000	365X290X200
CAP 2016	32	20,5	1.000	9,5	10	10.000	365X290X200

# Nailed Buttons



NB 1616



SNB 1616

ITEM CODE	NO	SHANK LENGTH	HEAD DIAMETER	PACKET PCS	BOX KG	BOX PACKET	BOX PCS	SIZE OF BOX
NB 1616 A	28	11	18	500	15,8	12	6.000	365X290X200
NB 1616 B	28	17	18	500	17,9	12	6.000	365X290X200
NB 1616 C	28	30	18	500	17,4	12	6.000	365X290X200
NB 1616 D	28	40	18	500	16,8	12	6.000	365X290X200
NB 1616 E	30	11	19	500	15,8	10	5.000	365X290X200
NB 1616 F	30	17	19	500	17,9	10	5.000	365X290X200
NB 1616 G	30	30	19	500	17,4	10	5.000	365X290X200
NB 1616 H	30	40	19	500	16,8	10	5.000	365X290X200
NB 1616 I	32	11	20,5	250	17,5	16	4.000	365X290X200
NB 1616 J	32	17	20,5	250	15,2	16	4.000	365X290X200
NB 1616 K	32	30	20,5	250	13,5	16	4.000	365X290X200
NB 1616 L	32	40	20,5	250	14,1	16	4.000	365X290X200
NB 1616 M	36	11	23	200	9,4	14	2.800	365X290X200
NB 1616 N	36	17	23	200	9,4	14	2.800	365X290X200
NB 1616 O	36	30	23	200	9,4	14	2.800	365X290X200
NB 1616 P	36	40	23	200	9,4	14	2.800	365X290X200
NB 1616 R	36	11	23	200	9,4	14	2.800	365X290X200
SNB 1616 A	28	17	18	500	15,8	12	6.000	365X290X200
SNB 1616 B	28	30	18	500	17,9	12	6.000	365X290X200
SNB 1616 C	28	40	18	500	17,4	12	6.000	365X290X200
SNB 1616 D	28	11	18	500	16,8	12	6.000	365X290X200
SNB 1616 E	30	17	19	500	15,8	10	5.000	365X290X200
SNB 1616 F	30	30	19	500	17,9	10	5.000	365X290X200
SNB 1616 G	30	40	19	500	17,4	10	5.000	365X290X200
SNB 1616 H	30	11	19	500	16,8	10	5.000	365X290X200
SNB 1616 I	32	17	20,5	250	17,5	16	4.000	365X290X200
SNB 1616 J	32	30	20,5	250	15,2	16	4.000	365X290X200
SNB 1616 K	32	40	20,5	250	13,5	16	4.000	365X290X200
SNB 1616 L	32	11	20,5	250	14,1	16	4.000	365X290X200
SNB 1616 M	36	17	23	200	9,4	14	2.800	365X290X200
SNB 1616 N	36	30	23	200	9,4	14	2.800	365X290X200
SNB 1616 O	36	40	23	200	9,4	14	2.800	365X290X200
SNB 1616 P	36	11	23	200	9,4	14	2.800	365X290X200
SNB 1616 R	36	17	23	200	9,4	14	2.800	365X290X200



# ZIPPER



## Zipper

- ✓ Zippers are used in sofas and beds. It is used in cushion covers, pillows in sofas and in mattress covers in beds. It is a universal product. You can use it for any purpose. There are products with different specifications and weights.
- ✓ All size of Derlin, Naylor, Metal zippers are located in our collection.
- ✓ Tape, Chain, Slider, Puller can be produced in desired colors and weights.
- ✓ Company logo or name also can be placed on the puller as special design.
- ✓ Puller can be any desired design.

# Zipper Types



T10 Nylon (ZT10)



T5 Nylon (ZT5)



T6 Derlin (ZDT6)



T8 Derlin (ZDT8)

## Zipper Chain Types

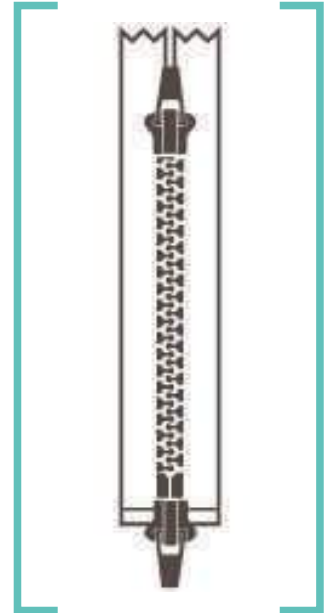
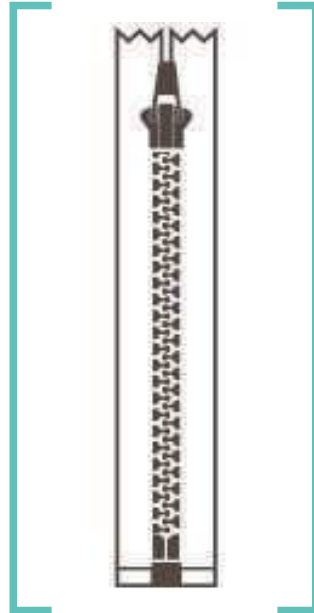
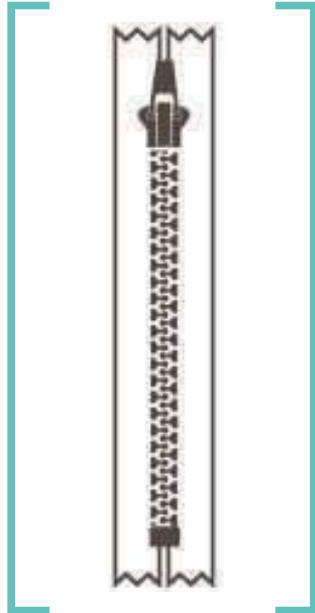
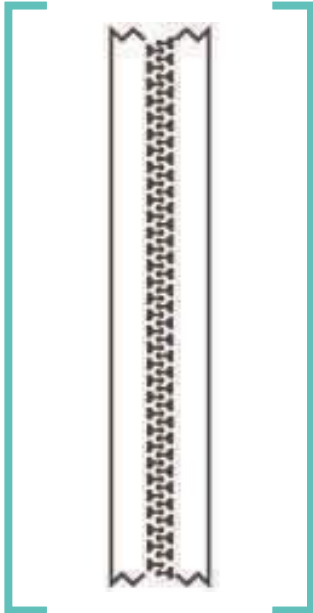

Standart Chain  
(ZSC 1616)

Close End Chain  
(ZCC 1616)

Open End Chain  
(ZOC 1616)

Two Ways Open Chain  
(ZTO 1616)

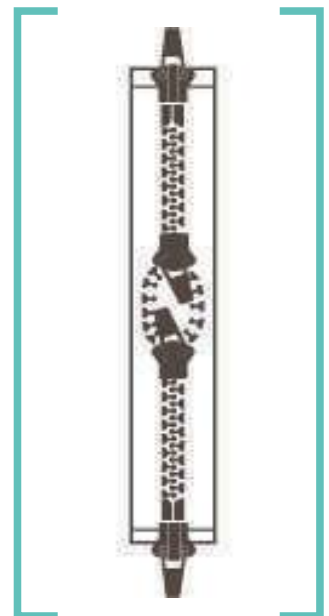
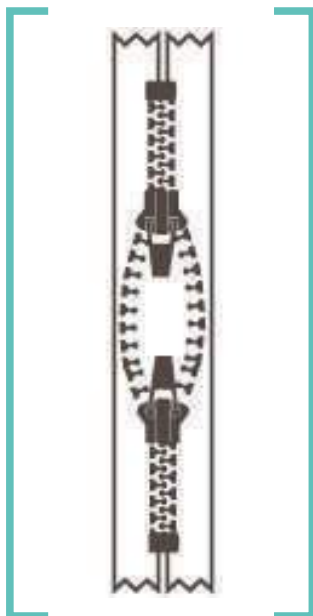

O Form Chain  
(ZOC 1616)

X Form Chain  
(ZXC 1616)

Y Form Chain  
(ZYC 1616)

Double Combi Chain  
(ZDC 1616)

# Zipper Tapes



ZF 1610



ZF 1611



ZF 1612



ZF 1613



ZF 1614



ZF 1615



ZF 1616



ZF 1617



ZF 1618



ZF 1619



ZF 16110



ZF 16111



ZF 16112



ZF 16113



ZF 16114



ZF 16115



ZF 16116



ZF 16117



ZF 16118



ZF 16119



ZF 16120



ZF 16121



ZF 16122



ZF 16123



ZF 16124



ZF 16125



ZF 16126

# Zipper Chain Colors



T5 1



T5 2



T5 3



T5 4



T10 1



T10 2



T10 3



T10 4



T10 5



T10 6



T10 7



T10 8



T10 9



T10 10



T10 11



T10 12



T10 13

# Zipper Slider Colors

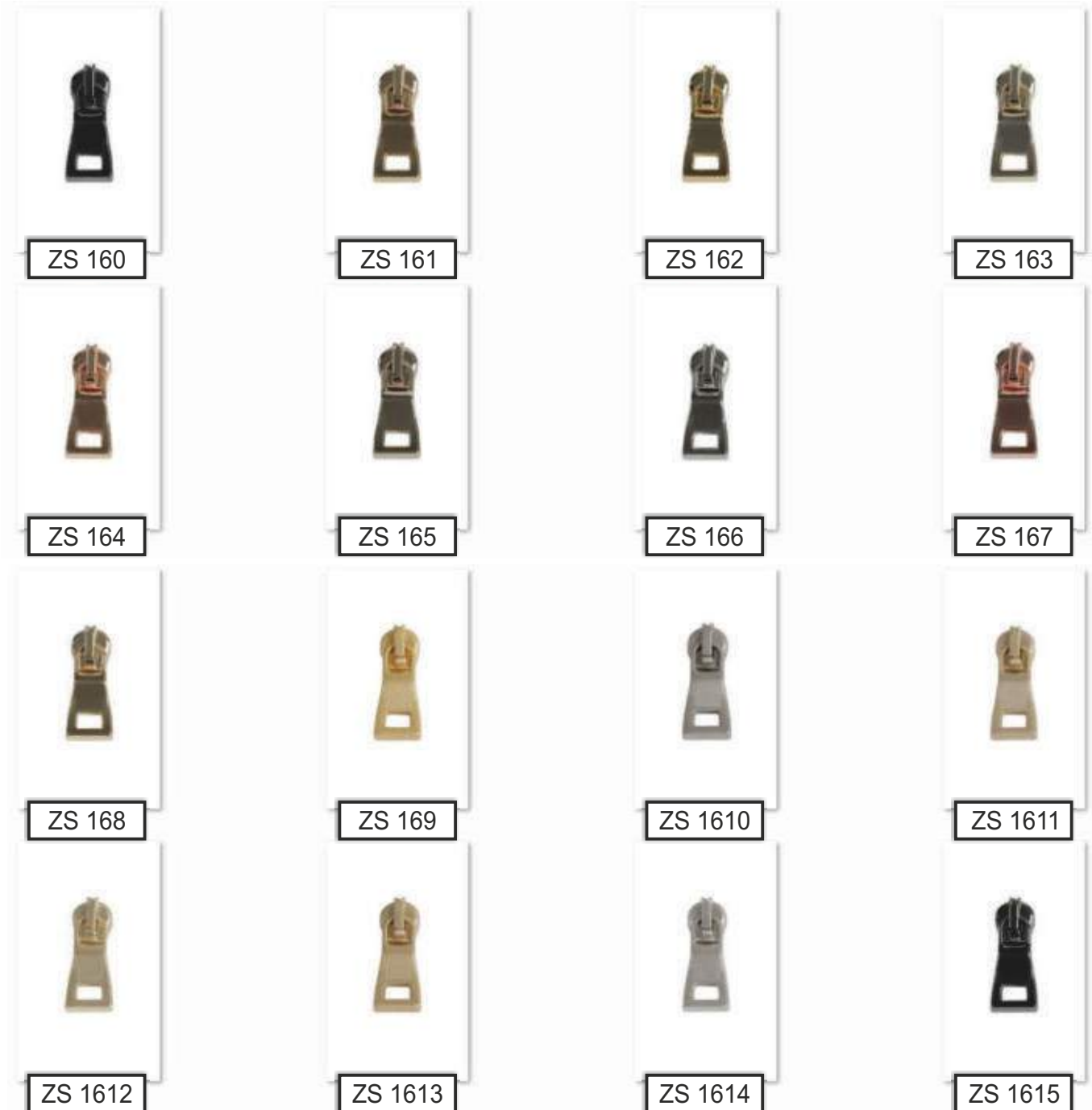

# Zipper Slider Colors

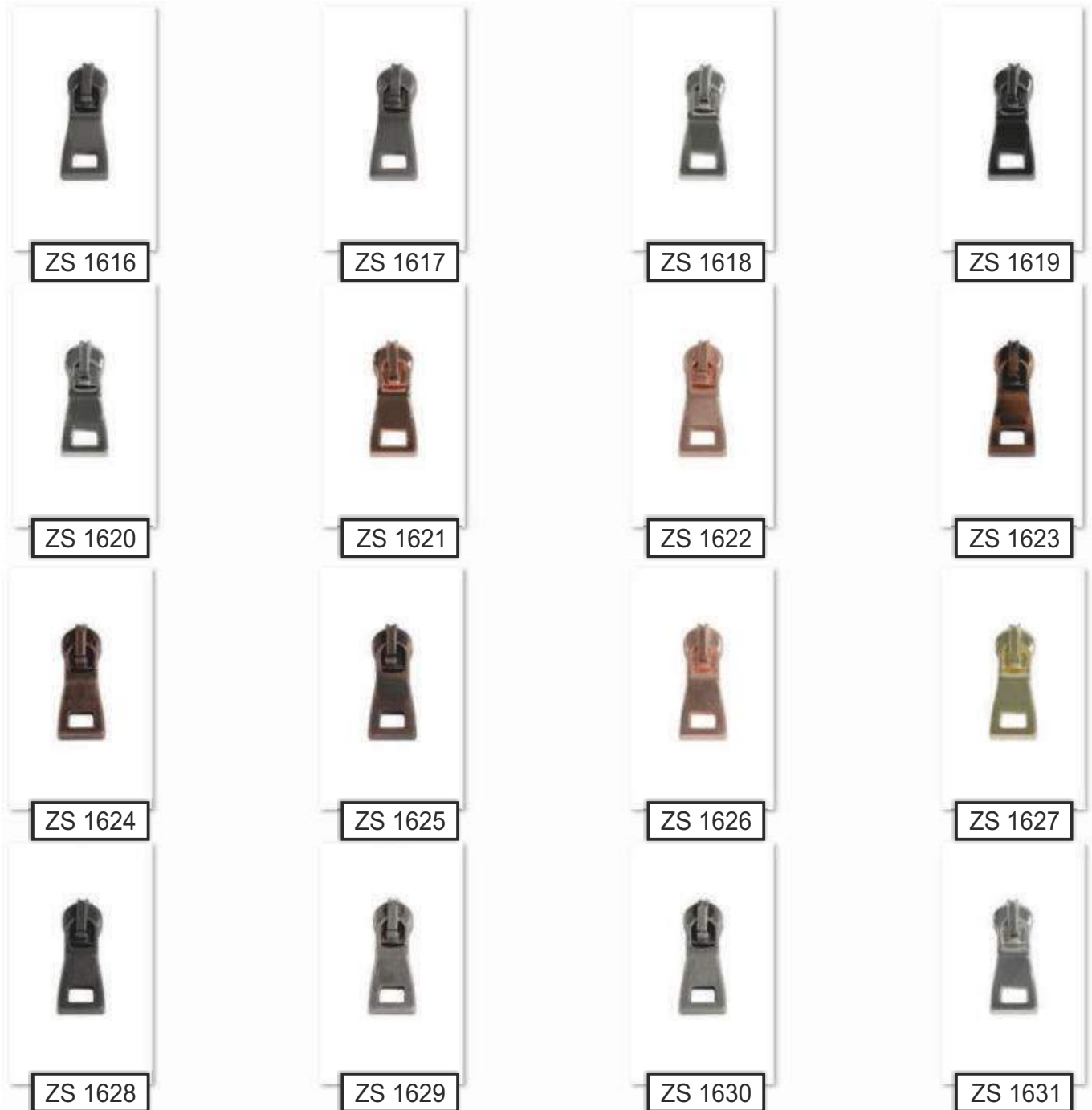

# Zipper Slider Colors

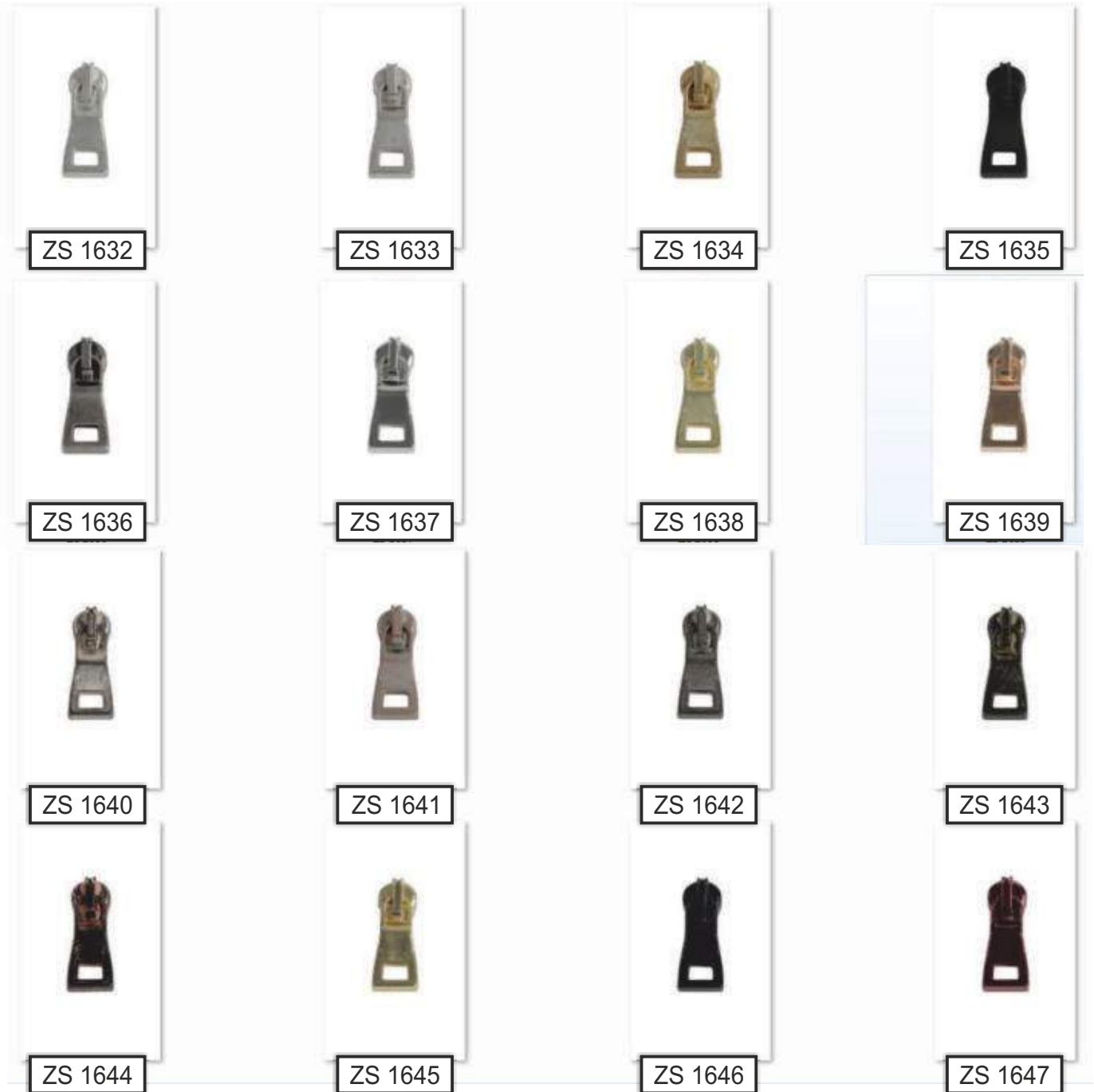

# Zipper Slider Colors



ZS 1648



ZS 1649



ZS 1650



ZS 1651



ZS 1652



ZS 1653



ZS 1654



ZS 1655

# Zipper Puller



ZF 160



ZF 161



ZF 162



ZF 163



ZF 164



ZF 165



ZF 166



ZF 167



ZF 168



ZF 169



ZF 1610



ZF 1611



ZF 1612



ZF 1613



ZF 1614



ZF 1615



ZF 1616



ZF 1617



ZF 1618



ZF 1619



ZF 1620



ZF 1621



ZF 1622



ZF 1623



ZF 1624

# Zipper Puller



ZF 1625



ZF 1626



ZF 1627



ZF 1628



ZF 1629



ZF 1630



ZF 1631



ZF 1632



ZF 1633



ZF 1634



ZF 1635



ZF 1636



ZF 1637



ZF 1638



ZF 1639



ZF 1640



ZF 1641



ZF 1642



ZF 1643



ZF 1644



ZF 1645



ZF 1646



ZF 1647



ZF 1648



ZF 1649

# Zipper Puller



ZF 1650



ZF 1651



ZF 1652



ZF 1653



ZF 1654



ZF 1655



ZF 1656



ZF 1657



ZF 1658



ZF 1659



ZF 1660



ZF 1661



ZF 1662



ZF 1663



ZF 1664



ZF 1665



ZF 1666



ZF 1667



ZF 1668



ZF 1669



ZF 1670



ZF 1671



ZF 1672



ZF 1673



ZF 1674

# Zipper Puller



ZF 1675



ZF 1676



ZF 1677



ZF 1678



ZF 1679



ZF 1680



ZF 1681



ZF 1682



ZF 1683



ZF 1684



ZF 1685



ZF 1686



ZF 1687



ZF 1688



# HOOK & LOOP



## Hook & Loop

- ✓ Hook and loop allow the relevant parts of armchairs, bases and mattresses to be attached as femalemale. It is sold as male and female. It is 25 mt. as set. It is 2 cm. and 5 cm. in standard.
- ✓ It can be produced in desired width and color as well.
- ✓ It can be produced as nylon and nylon&polyester mix in desired percentage.

# komi

Your Supply Chain Partner

## HEAD OFFICE

Konak Mah. 1. Badem Sk. Lotus Plaza B Blok  
1. Kat Daire:6 No:26 ZIP:16110 Nilüfer  
Bursa / Türkiye

+90 555 880 23 16  
office@komiteks.com  
www.komiteks.com